

# International Journal of Research in Advanced Electronics Engineering



E-ISSN: 2708-4566  
P-ISSN: 2708-4558  
IJRAEE 2022; 3(1): 78-99  
© 2020 IJRAEE  
[www.electrojournal.com](http://www.electrojournal.com)  
Received: 17-01-2022  
Accepted: 19-03-2022

**EL Pankratov**  
Nizhny Novgorod State  
University, 23 Gagarin  
Avenue, Nizhny Novgorod,  
Russia

## On optimization of manufacturing of a voltage doubler

**EL Pankratov**

### Abstract

In this paper we consider a possibility to increase density of field-effect heterotransistors framework a voltage doubler due to decreasing of their dimensions. The considered approach based on doping of required areas of heterostructure with specific configuration by diffusion or ion implantation. The doping finished by optimized annealing of dopant and/or radiation defects. Analysis of redistribution of dopant with account redistribution of radiation defects (after implantation of ions of dopant) for optimization of the above annealing have been done by using recently introduced analytical approach. The approach gives a possibility to analyze mass and heat transports in a heterostructure without crosslinking of solutions on interfaces between layers of the heterostructure with account nonlinearity of these transports and variation in time of their parameters.

**Keywords:** Manufacturing of a voltage, heterotransistors framework, analytical

### Introduction

In the present time an actual question is decreasing of dimensions of solid state electronic devices. To decrease the dimensions are could be increased density of elements of integrated circuits and decreased dimensions of these elements. To date, several methods to decrease dimensions of elements of integrated circuits have been developed. One of them is growth of thin films structures <sup>[1-5]</sup>. The second approach is diffusion or ion doping of required areas of samples or heterostructures and further laser or microwave annealing of dopant and/or radiation defects <sup>[6-8]</sup>. Using of the above approaches of annealing leads to generation of in homogenous distribution of temperature and consequently to decreasing of dimensions of elements of integrated circuits. Another approach to change properties of doped materials is radiation processing <sup>[9, 10]</sup>.

In this paper we consider an approach to increase density of elements of circuit of a voltage doubler based on field-effect heterotransistors <sup>[11]</sup>. To illustrate the approach we consider a heterostructure, which consist of a substrate and an epitaxial layer. The epitaxial layer includes into itself several sections manufactured by using another materials. These sections have been doped by diffusion or ion implantation to generation required types of conductivity ( $p$  or  $n$ ) to manufacture bipolar transistors so as it is shown on Fig. 1. After finishing of the doping we consider annealing of dopant and/or radiation defects (after implantation of ions of dopant). Main aim of the present paper is optimization of annealing of the dopant.

**Correspondence**  
**EL Pankratov**  
Nizhny Novgorod State  
University, 23 Gagarin  
Avenue, Nizhny Novgorod,  
Russia

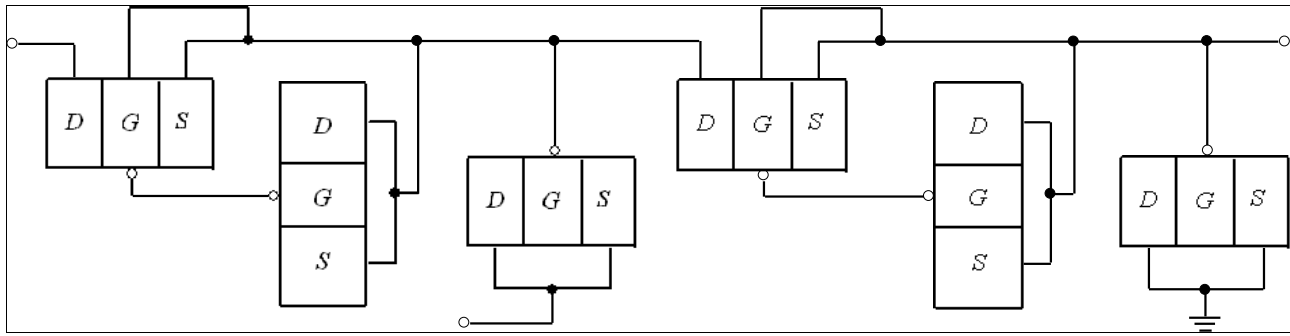


Fig 1: Structure of voltage doubler [11]. View from top

**Method of analysis**

To solve our aims let us determine spatio-temporal distributions of concentrations of dopants. The required distributions we determined by solving the second Fick's law [9, 10, 12, 13].

$$\frac{\partial C(x, y, z, t)}{\partial t} = \frac{\partial}{\partial x} \left[ D_c \frac{\partial C(x, y, z, t)}{\partial x} \right] + \frac{\partial}{\partial y} \left[ D_c \frac{\partial C(x, y, z, t)}{\partial y} \right] + \frac{\partial}{\partial z} \left[ D_c \frac{\partial C(x, y, z, t)}{\partial z} \right] \tag{1}$$

with boundary and initial conditions

$$\begin{aligned} \left. \frac{\partial C(x, y, z, t)}{\partial x} \right|_{x=0} = 0, \quad \left. \frac{\partial C(x, y, z, t)}{\partial x} \right|_{x=L_x} = 0, \quad \left. \frac{\partial C(x, y, z, t)}{\partial y} \right|_{y=0} = 0, \quad \left. \frac{\partial C(x, y, z, t)}{\partial y} \right|_{y=L_y} = 0, \\ \left. \frac{\partial C(x, y, z, t)}{\partial z} \right|_{z=0} = 0, \quad \left. \frac{\partial C(x, y, z, t)}{\partial z} \right|_{z=L_z} = 0, \quad C(x, y, z, 0) = f(x, y, z). \end{aligned} \tag{2}$$

Here  $C(x, y, z, t)$  is the spatio-temporal distribution of concentration of dopant;  $T$  is the temperature of annealing;  $D_c$  is the dopant diffusion coefficient. Value of dopant diffusion coefficient depends on properties of materials, speed of heating and cooling of heterostructure (with account Arrhenius law). Dependences of dopant diffusion coefficient on parameters could be approximated by the following relation [10, 12]

$$D_c = D_L(x, y, z, T) \left[ 1 + \xi \frac{C^\gamma(x, y, z, t)}{P^\gamma(x, y, z, T)} \right] \left[ 1 + \zeta_1 \frac{V(x, y, z, t)}{V^*} + \zeta_2 \frac{V^2(x, y, z, t)}{(V^*)^2} \right], \tag{3}$$

where  $D_L(x, y, z, T)$  is the spatial (due to inhomogeneity of heterostructure) and temperature (due to Arrhenius law) dependences of diffusion coefficient;  $P(x, y, z, T)$  is the limit of solubility of dopant; parameter  $\gamma$  depends on properties of materials and could be integer in the following interval;  $V(x, y, z, t)$  is the spatio-temporal distribution of concentration of vacancies;  $V^*$  is the equilibrium distribution of vacancies. Concentrational dependence of dopant diffusion coefficient is describes in details in [12]. It should be noted, that using diffusive type of doping did not leads to radiation damage. In this situation  $\zeta_1 = \zeta_2 = 0$ . We determine spatio-temporal distributions of concentrations of point radiation defects by solution the following system of equations [10, 13]

$$\begin{aligned} \frac{\partial I(x, y, z, t)}{\partial t} = \frac{\partial}{\partial x} \left[ D_I(x, y, z, T) \frac{\partial I(x, y, z, t)}{\partial x} \right] + \frac{\partial}{\partial y} \left[ D_I(x, y, z, T) \frac{\partial I(x, y, z, t)}{\partial y} \right] + \\ + \frac{\partial}{\partial z} \left[ D_I(x, y, z, T) \frac{\partial I(x, y, z, t)}{\partial z} \right] - k_{I,V}(x, y, z, T) I(x, y, z, t) V(x, y, z, t) - \end{aligned}$$

$$-k_{I,I}(x, y, z, T)I^2(x, y, z, t) \quad (4)$$

$$\begin{aligned} \frac{\partial V(x, y, z, t)}{\partial t} &= \frac{\partial}{\partial x} \left[ D_V(x, y, z, T) \frac{\partial V(x, y, z, t)}{\partial x} \right] + \frac{\partial}{\partial y} \left[ D_V(x, y, z, T) \frac{\partial V(x, y, z, t)}{\partial y} \right] + \\ &+ \frac{\partial}{\partial z} \left[ D_V(x, y, z, T) \frac{\partial V(x, y, z, t)}{\partial z} \right] - k_{I,V}(x, y, z, T)I(x, y, z, t)V(x, y, z, t) - \\ &- k_{V,V}(x, y, z, T)V^2(x, y, z, t) \end{aligned}$$

With boundary

$$\rho(x, y, z, 0) = f_\rho(x, y, z) \quad (5a)$$

and initial conditions

$$\begin{aligned} \left. \frac{\partial \rho(x, y, z, t)}{\partial x} \right|_{x=0} &= 0, \quad \left. \frac{\partial \rho(x, y, z, t)}{\partial x} \right|_{x=L_x} = 0, \quad \left. \frac{\partial \rho(x, y, z, t)}{\partial y} \right|_{y=0} = 0, \\ \left. \frac{\partial \rho(x, y, z, t)}{\partial y} \right|_{y=L_y} &= 0, \quad \left. \frac{\partial \rho(x, y, z, t)}{\partial z} \right|_{z=0} = 0, \quad \left. \frac{\partial \rho(x, y, z, t)}{\partial z} \right|_{z=L_z} = 0 \end{aligned} \quad (5b)$$

Here  $\rho = I, V$ ;  $I(x, y, z, t)$  are the spatio-temporal distributions of concentrations of interstitials;  $D_\rho(x, y, z, T)$  is the diffusion coefficients of interstitials and vacancies; terms  $V^2(x, y, z, t)$  and  $I^2(x, y, z, t)$  correspond to generation of divacancies and diinterstitials;  $k_{I,V}(x, y, z, T)$ ,  $k_{I,I}(x, y, z, T)$  and  $k_{V,V}(x, y, z, T)$  are the parameters of recombination of point defects and generation their complexes.

We determine spatio-temporal distributions of concentration of divacancies  $\Phi_V(x, y, z, t)$  and interstitials  $\Phi_I(x, y, z, t)$  by solving following systems of equations<sup>[10, 13]</sup>

$$\begin{aligned} \frac{\partial \Phi_I(x, y, z, t)}{\partial t} &= \frac{\partial}{\partial x} \left[ D_{\Phi_I}(x, y, z, T) \frac{\partial \Phi_I(x, y, z, t)}{\partial x} \right] + k_{I,I}(x, y, z, T)I^2(x, y, z, t) + \\ &+ \frac{\partial}{\partial y} \left[ D_{\Phi_I}(x, y, z, T) \frac{\partial \Phi_I(x, y, z, t)}{\partial y} \right] + \frac{\partial}{\partial z} \left[ D_{\Phi_I}(x, y, z, T) \frac{\partial \Phi_I(x, y, z, t)}{\partial z} \right] - \\ &- k_I(x, y, z, T)I(x, y, z, t) \end{aligned} \quad (6)$$

$$\begin{aligned} \frac{\partial \Phi_V(x, y, z, t)}{\partial t} &= \frac{\partial}{\partial x} \left[ D_{\Phi_V}(x, y, z, T) \frac{\partial \Phi_V(x, y, z, t)}{\partial x} \right] + k_{V,V}(x, y, z, T)V^2(x, y, z, t) + \\ &+ \frac{\partial}{\partial y} \left[ D_{\Phi_V}(x, y, z, T) \frac{\partial \Phi_V(x, y, z, t)}{\partial y} \right] + \frac{\partial}{\partial z} \left[ D_{\Phi_V}(x, y, z, T) \frac{\partial \Phi_V(x, y, z, t)}{\partial z} \right] - \\ &- k_V(x, y, z, T)V(x, y, z, t) \end{aligned}$$

with boundary and initial conditions

$$\left. \frac{\partial \Phi_\rho(x, y, z, t)}{\partial x} \right|_{x=0} = 0, \left. \frac{\partial \Phi_\rho(x, y, z, t)}{\partial x} \right|_{x=L_x} = 0, \left. \frac{\partial \Phi_\rho(x, y, z, t)}{\partial y} \right|_{y=0} = 0,$$

$$\left. \frac{\partial \Phi_\rho(x, y, z, t)}{\partial y} \right|_{y=L_y} = 0, \left. \frac{\partial \Phi_\rho(x, y, z, t)}{\partial z} \right|_{z=0} = 0, \left. \frac{\partial \Phi_\rho(x, y, z, t)}{\partial z} \right|_{z=L_z} = 0,$$

$$\Phi_I(x, y, z, 0) = f\phi_I(x, y, z), \Phi_V(x, y, z, 0) = f\phi_V(x, y, z). \quad (7)$$

Here  $D_{\phi_I}(x, y, z, T)$  and  $D_{\phi_V}(x, y, z, T)$  are the diffusion coefficients of simplest complexes of radiation defects;  $k_I(x, y, z, T)$  and  $k_V(x, y, z, T)$  are the parameters of decay of complexes of point defects.

To determine spatio-temporal distributions of concentrations of point radiation defects we used recently elaborated approach [14, 15]. Framework the approach we transform approximations of diffusion coefficients in the following form:  $D_{\rho}(x, y, z, T) = D_{0\rho} [1 + \varepsilon_\rho g_\rho(x, y, z, T)]$ , where  $D_{0\rho}$  are the average values of diffusion coefficients,  $0 \leq \varepsilon_\rho < 1$ ,  $|g_\rho(x, y, z, T)| \leq 1$ ,  $\rho = I, V$ . We also used analogous transformation of approximations of parameters of recombination of point defects and parameters of generation of their complexes:  $k_{I,V}(x, y, z, T) = k_{0I,V} [1 + \varepsilon_{I,V} g_{I,V}(x, y, z, T)]$ ,  $k_{II}(x, y, z, T) = k_{0II} [1 + \varepsilon_{II} g_{II}(x, y, z, T)]$  and  $k_{V,V}(x, y, z, T) = k_{0V,V} [1 + \varepsilon_{V,V} g_{V,V}(x, y, z, T)]$ , where  $k_{0\rho 1, \rho 2}$  are the their average values,  $0 \leq \varepsilon_{I,V} < 1$ ,  $0 \leq \varepsilon_{II} < 1$ ,  $0 \leq \varepsilon_{V,V} < 1$ ,  $|g_{I,V}(x, y, z, T)| \leq 1$ ,  $|g_{II}(x, y, z, T)| \leq 1$ ,  $|g_{V,V}(x, y, z, T)| \leq 1$ . Let us introduce the following dimensionless variables:

$$\tilde{I}(x, y, z, t) = I(x, y, z, t) / I^*, \chi = x / L_x, \tilde{V}(x, y, z, t) = V(x, y, z, t) / V^*, \vartheta = \sqrt{D_{0I} D_{0V}} t / L^2,$$

$$\omega = L^2 k_{0I,V} / \sqrt{D_{0I} D_{0V}}, \eta = y / L_y, \phi = z / L_z, \Omega_\rho = L^2 k_{0\rho, \rho} / \sqrt{D_{0I} D_{0V}}.$$

The introduction leads to transformation of Eqs. (4) and conditions (5) to the following form

$$\frac{\partial \tilde{I}(\chi, \eta, \phi, \vartheta)}{\partial \vartheta} = \frac{D_{0I}}{\sqrt{D_{0I} D_{0V}}} \frac{\partial}{\partial \chi} \left\{ [1 + \varepsilon_I g_I(\chi, \eta, \phi, T)] \frac{\partial \tilde{I}(\chi, \eta, \phi, \vartheta)}{\partial \chi} \right\} + \frac{D_{0I}}{\sqrt{D_{0I} D_{0V}}} \times$$

$$+ \frac{\partial}{\partial \eta} \left\{ [1 + \varepsilon_I g_I(\chi, \eta, \phi, T)] \frac{\partial \tilde{I}(\chi, \eta, \phi, \vartheta)}{\partial \eta} \right\} + \frac{D_{0I}}{\sqrt{D_{0I} D_{0V}}} \frac{\partial}{\partial \phi} \left\{ [1 + \varepsilon_I g_I(\chi, \eta, \phi, T)] \times \right.$$

$$\times \left. \frac{\partial \tilde{I}(\chi, \eta, \phi, \vartheta)}{\partial \phi} \right\} - \omega [1 + \varepsilon_{I,V} g_{I,V}(\chi, \eta, \phi, T)] \tilde{I}(\chi, \eta, \phi, \vartheta) \tilde{V}(\chi, \eta, \phi, \vartheta) -$$

$$- \Omega_I [1 + \varepsilon_{I,I} g_{I,I}(\chi, \eta, \phi, T)] \tilde{I}^2(\chi, \eta, \phi, \vartheta) \quad (8)$$

$$\frac{\partial \tilde{V}(\chi, \eta, \phi, \vartheta)}{\partial \vartheta} = \frac{D_{0V}}{\sqrt{D_{0I} D_{0V}}} \frac{\partial}{\partial \chi} \left\{ [1 + \varepsilon_V g_V(\chi, \eta, \phi, T)] \frac{\partial \tilde{V}(\chi, \eta, \phi, \vartheta)}{\partial \chi} \right\} + \frac{D_{0V}}{\sqrt{D_{0I} D_{0V}}} \times$$

$$+ \frac{\partial}{\partial \eta} \left\{ [1 + \varepsilon_V g_V(\chi, \eta, \phi, T)] \frac{\partial \tilde{V}(\chi, \eta, \phi, \vartheta)}{\partial \eta} \right\} + \frac{D_{0V}}{\sqrt{D_{0I} D_{0V}}} \frac{\partial}{\partial \phi} \left\{ [1 + \varepsilon_V g_V(\chi, \eta, \phi, T)] \times \right.$$

$$\times \left. \frac{\partial \tilde{V}(\chi, \eta, \phi, \vartheta)}{\partial \phi} \right\} - \omega [1 + \varepsilon_{I,V} g_{I,V}(\chi, \eta, \phi, T)] \tilde{I}(\chi, \eta, \phi, \vartheta) \tilde{V}(\chi, \eta, \phi, \vartheta) -$$

$$- \Omega_V [1 + \varepsilon_{V,V} g_{V,V}(\chi, \eta, \phi, T)] \tilde{V}^2(\chi, \eta, \phi, \vartheta)$$

$$\left. \frac{\partial \tilde{\rho}(\chi, \eta, \phi, \vartheta)}{\partial \chi} \right|_{\chi=0} = 0, \left. \frac{\partial \tilde{\rho}(\chi, \eta, \phi, \vartheta)}{\partial \chi} \right|_{\chi=1} = 0, \left. \frac{\partial \tilde{\rho}(\chi, \eta, \phi, \vartheta)}{\partial \eta} \right|_{\eta=0} = 0, \left. \frac{\partial \tilde{\rho}(\chi, \eta, \phi, \vartheta)}{\partial \eta} \right|_{\eta=1} = 0,$$

$$\left. \frac{\partial \tilde{\rho}(\chi, \eta, \phi, \vartheta)}{\partial \phi} \right|_{\phi=0} = 0, \left. \frac{\partial \tilde{\rho}(\chi, \eta, \phi, \vartheta)}{\partial \phi} \right|_{\phi=1} = 0, \tilde{\rho}(\chi, \eta, \phi, \vartheta) = \frac{f_{\rho}(\chi, \eta, \phi, \vartheta)}{\rho^*}. \quad (9)$$

We determine solutions of Eqs.(8) with conditions (9) framework recently introduced approach [14,15], i.e. as the power series

$$\tilde{\rho}(\chi, \eta, \phi, \vartheta) = \sum_{i=0}^{\infty} \varepsilon_{\rho}^i \sum_{j=0}^{\infty} \omega^j \sum_{k=0}^{\infty} \Omega_{\rho}^k \tilde{\rho}_{ijk}(\chi, \eta, \phi, \vartheta). \quad (10)$$

Substitution of the series (10) into Eqs. (8) and conditions (9) gives us possibility to obtain equations for initial-order approximations of concentration of point defects  $\tilde{I}_{000}(\chi, \eta, \phi, \vartheta)$  and  $\tilde{V}_{000}(\chi, \eta, \phi, \vartheta)$  and corrections for them

$$\tilde{I}_{ijk}(\chi, \eta, \phi, \vartheta) \text{ and } \tilde{V}_{ijk}(\chi, \eta, \phi, \vartheta),$$

$i \geq 1, j \geq 1, k \geq 1$ . The equations are presented in the Appendix. Solutions of the equations could be obtained by standard Fourier approach [16, 17]. The solutions are presented in the Appendix.

Farther we determine spatio-temporal distributions of concentrations of simplest complexes of point radiation defects. To determine the distributions we transform approximations of diffusion coefficients in the following form:  $D_{\phi\rho}(x, y, z, T) = D_{0\phi\rho}[1 + \varepsilon_{\phi\rho}g_{\phi\rho}(x, y, z, T)]$ , where  $D_{0\phi\rho}$  are the average values of diffusion coefficients. In this situation the Eqs.(6) could be written as

$$\frac{\partial \Phi_I(x, y, z, t)}{\partial t} = D_{0\phi I} \frac{\partial}{\partial x} \left\{ [1 + \varepsilon_{\phi I} g_{\phi I}(x, y, z, T)] \frac{\partial \Phi_I(x, y, z, t)}{\partial x} \right\} +$$

$$+ D_{0\phi I} \frac{\partial}{\partial y} \left\{ [1 + \varepsilon_{\phi I} g_{\phi I}(x, y, z, T)] \frac{\partial \Phi_I(x, y, z, t)}{\partial y} \right\} + D_{0\phi I} \frac{\partial}{\partial z} \left\{ \frac{\partial \Phi_I(x, y, z, t)}{\partial z} \times \right.$$

$$\left. \times [1 + \varepsilon_{\phi I} g_{\phi I}(x, y, z, T)] \right\} + k_{I,I}(x, y, z, T) I^2(x, y, z, t) - k_I(x, y, z, T) I(x, y, z, t)$$

$$\frac{\partial \Phi_V(x, y, z, t)}{\partial t} = D_{0\phi V} \frac{\partial}{\partial x} \left\{ [1 + \varepsilon_{\phi V} g_{\phi V}(x, y, z, T)] \frac{\partial \Phi_V(x, y, z, t)}{\partial x} \right\} +$$

$$+ D_{0\phi V} \frac{\partial}{\partial y} \left\{ [1 + \varepsilon_{\phi V} g_{\phi V}(x, y, z, T)] \frac{\partial \Phi_V(x, y, z, t)}{\partial y} \right\} + D_{0\phi V} \frac{\partial}{\partial z} \left\{ \frac{\partial \Phi_V(x, y, z, t)}{\partial z} \times \right.$$

$$\left. \times [1 + \varepsilon_{\phi V} g_{\phi V}(x, y, z, T)] \right\} + k_{I,I}(x, y, z, T) I^2(x, y, z, t) - k_I(x, y, z, T) I(x, y, z, t).$$

Farther we determine solutions of above equations as the following power series

$$\Phi_{\rho}(x, y, z, t) = \sum_{i=0}^{\infty} \varepsilon_{\phi\rho}^i \Phi_{\rho i}(x, y, z, t). \quad (11)$$

Substitution of the series (11) into Eqs. (6) and appropriate boundary and initial conditions gives us possibility to obtain equations for initial-order approximations of concentrations of complexes of defects  $\Phi_{p0}(x, y, z, t)$  and corrections for them  $\Phi_{pi}(x, y, z, t), i \geq 1$  and boundary and initial conditions for them. The equations and conditions are presented in the Appendix. Solutions of the equations have been calculated by standard Fourier approaches [16, 17] and presented in the Appendix. We determine spatio-temporal distribution of concentration of dopant by using the same approach, which was used for calculation spatio-temporal distribution of concentration of radiation defects. Framework the approach we transform approximation of dopant diffusion coefficient to the following form:  $D_L(x, y, z, T) = D_{0L}[1 + \varepsilon_L g_L(x, y, z, T)]$ , where  $D_{0L}$  is the average value of dopant diffusion coefficient,  $0 \leq \varepsilon_L < 1, |g_L(x, y, z, T)| \leq 1$ . Farther we determine solution of Eq. (1) as the following power series

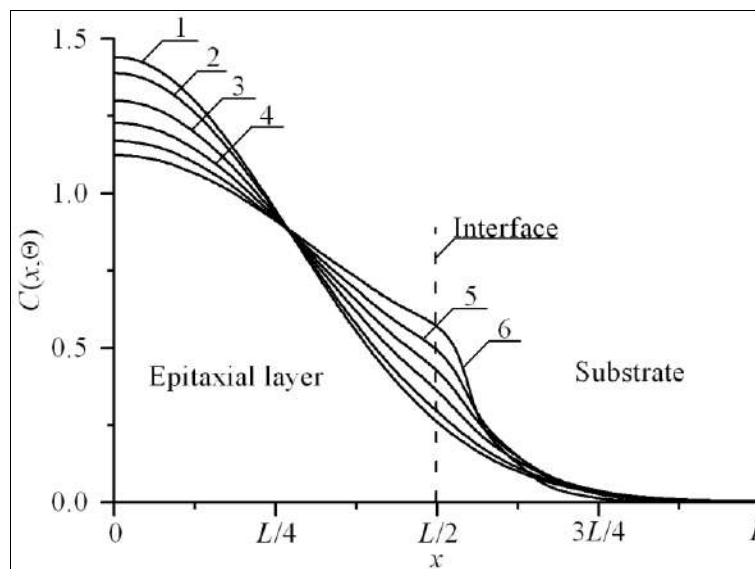
$$C(x, y, z, t) = \sum_{i=0}^{\infty} \varepsilon_L^i \sum_{j=1}^{\infty} \xi^j C_{ij}(x, y, z, t).$$

Substitution of the series into Eq.(1) and conditions (2) gives us possibility to obtain equations for the initial-order approximation of concentration of dopant  $C_{00}(x, y, z, t)$  and corrections for them  $C_{ij}(x, y, z, t) (i \geq 1, j \geq 1)$ , boundary and initial conditions for the equations. The equations are presented in the Appendix. Solutions of the equations have been calculated by standard Fourier approaches [16, 17]. The solutions are presented in the Appendix.

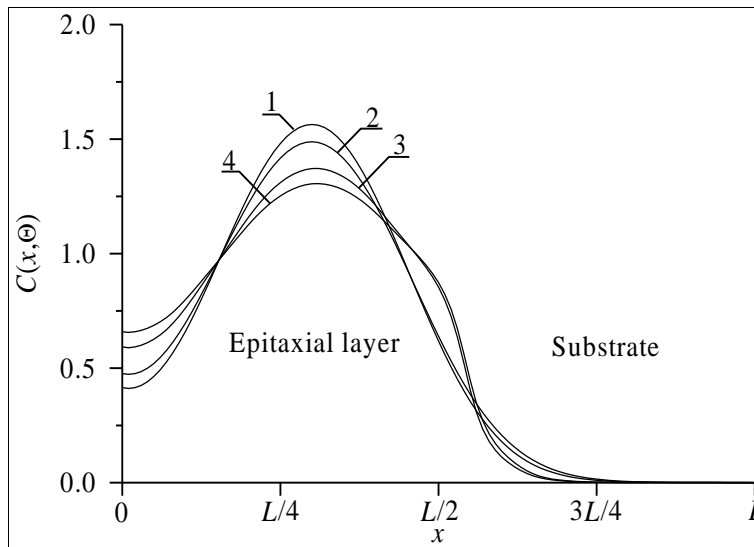
Analysis of spatio-temporal distributions of concentrations of dopant and radiation defects have been done analytically by using the second-order approximations on all parameters, which have been used in appropriate series. Usually the second-order approximations is enough good approximations to make qualitative analysis and to obtain quantitative results. All results of analytical modeling have been checked by comparison with results of numerical simulation.

**Discussion**

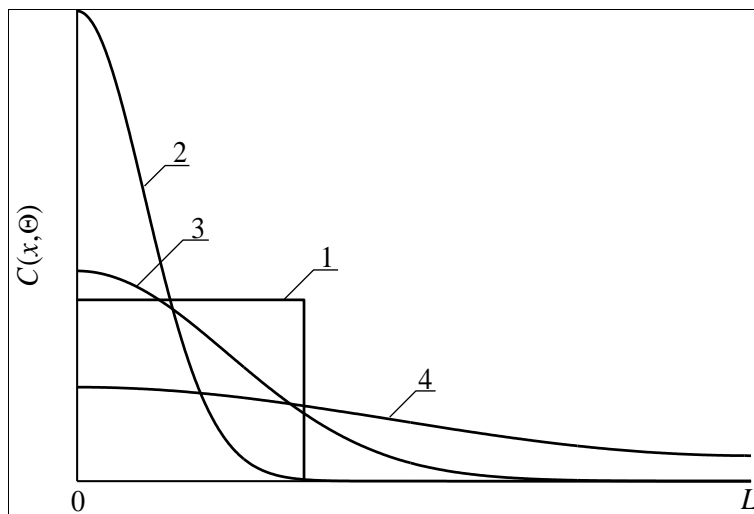
In this section we analyzed spatio-temporal distributions of concentrations of dopants by using recently calculated relations. Figs. 2 shows typical spatial distributions of concentrations of dopants in neighborhood of an interface between materials of heterostructures in direction, which is perpendicular to the interface. These distributions have been calculated for the case, when value of dopant diffusion coefficient in doped area is larger, than value of dopant diffusion coefficient in nearest areas. In this situation one can find increasing of compactness of distribution of concentration of dopant. At the same time one can find increasing homogeneity of dopant distribution in the doped part of epitaxial layer. The effect leads to decreasing local heating of materials during functioning of transistor or decreasing the dimensions of the transistor for fixed maximal value of local overheat. However, applications of this approach



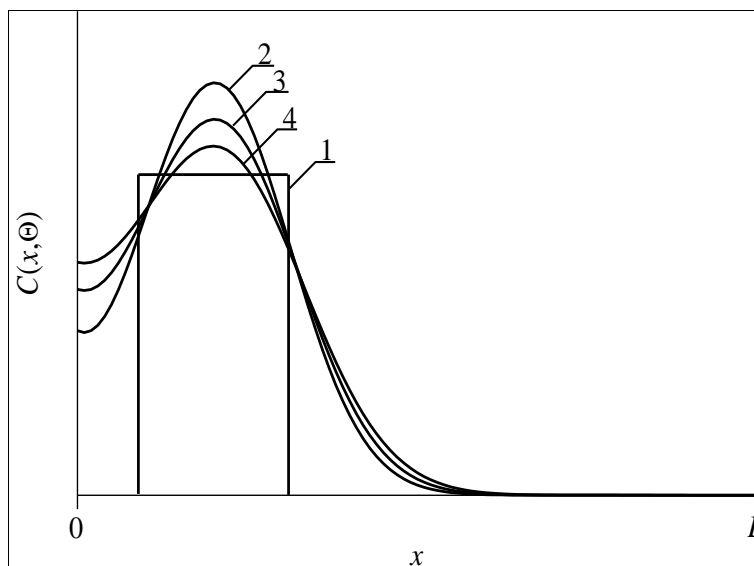
**Fig 2a:** Distributions of concentration of infused dopant in heterostructure from Figs. 1 in direction, which is perpendicular to interface between epitaxial layer substrate. Increasing of number of curve corresponds to increasing of difference between values of dopant diffusion coefficient in layers of heterostructure under condition, when value of dopant diffusion coefficient in epitaxial layer is larger, than value of dopant diffusion coefficient in substrate



**Fig 2b:** Distributions of concentration of implanted dopant in heterostructure from Figs. 1 and 2 in direction, which is perpendicular to interface between epitaxial layer substrate. Curves 1 and 3 corresponds to annealing time  $\Theta = 0.0048(L_x^2+L_y^2+L_z^2)/D_0$ . Curves 2 and 4 corresponds to annealing time  $\Theta = 0.0057(L_x^2+L_y^2+L_z^2)/D_0$ . Curves 1 and 2 corresponds to homogenous sample. Curves 3 and 4 corresponds to heterostructure under condition, when value of dopant diffusion coefficient in epitaxial layer is larger, than value of dopant diffusion coefficient in substrate

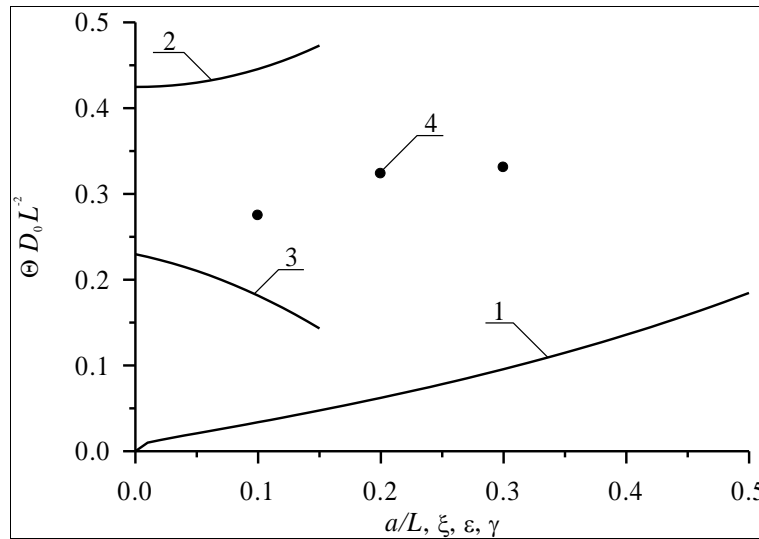


**Fig 3a:** Spatial distributions of dopant in heterostructure after dopant infusion. Curve 1 is idealized distribution of dopant. Curves 2-4 are real distributions of dopant for different values of annealing time. Increasing of number of curve corresponds to increasing of annealing time

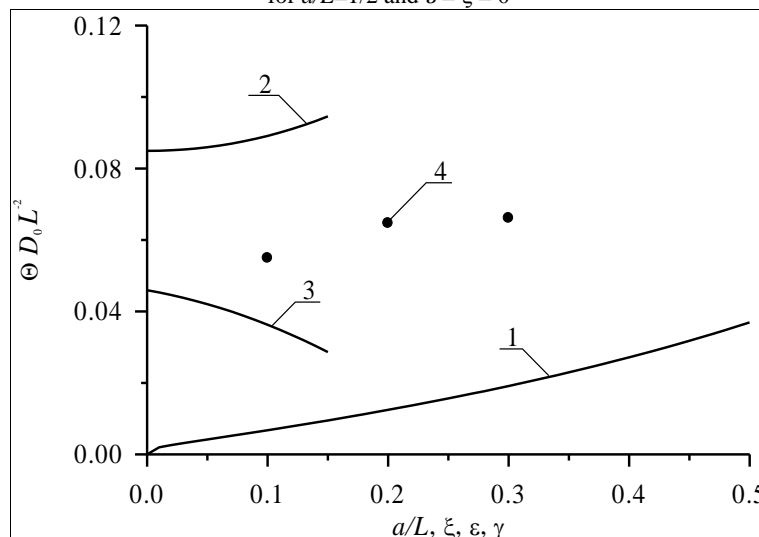


**Fig 3b:** Spatial distributions of dopant in heterostructure after ion implantation. Curve 1 is idealized distribution of dopant. Curves 2-4 are real distributions of dopant for different values of annealing time. Increasing of number of curve corresponds to increasing of annealing time

Of manufacturing of transistor required optimization annealing of dopant and/or radiation defects. The main reason for this optimization is following. If the annealing time is small, the dopant does not achieves any interfaces between the materials of heterostructure (see Figs. 3). In this situation one cannot find any modifications of the distribution of concentration of dopant. If the annealing time is large, the distribution of concentration of dopant is too homogenous. We optimize the annealing time based on a recently introduced approach [14, 15, 18-21]. By applying this criterion the criterion we approximate real distribution of concentration of dopant by a step-wise function (see Figs. 4). Next we determine optimal values of annealing time by minimization of the following mean-squared error.



**Fig 4a:** Dependences of dimensionless optimal annealing time for doping by diffusion, which have been obtained by minimization of mean-squared error, on several parameters. Curve 1 is the dependence of dimensionless optimal annealing time on the relation  $a/L$  and  $\xi = \gamma = 0$  for equal to each other values of dopant diffusion coefficient in all parts of heterostructure. Curve 2 is the dependence of dimensionless optimal annealing time on value of parameter  $\varepsilon$  for  $a/L=1/2$  and  $\xi = \gamma = 0$ . Curve 3 is the dependence of dimensionless optimal annealing time on value of parameter  $\xi$  for  $a/L=1/2$  and  $\varepsilon = \gamma = 0$ . Curve 4 is the dependence of dimensionless optimal annealing time on value of parameter  $\gamma$  for  $a/L=1/2$  and  $\varepsilon = \xi = 0$



**Fig 4:** Dependences of dimensionless optimal annealing time for doping by ion implantation, which have been obtained by minimization of mean-squared error, on several parameters. Curve 1 is the dependence of dimensionless optimal annealing time on the relation  $a/L$  and  $\xi = \gamma = 0$  for equal to each other values of dopant diffusion coefficient in all parts of heterostructure. Curve 2 is the dependence of dimensionless optimal annealing time on value of parameter  $\varepsilon$  for  $a/L=1/2$  and  $\xi = \gamma = 0$ . Curve 3 is the dependence of dimensionless optimal annealing time on value of parameter  $\xi$  for  $a/L=1/2$  and  $\varepsilon = \gamma = 0$ . Curve 4 is the dependence of dimensionless optimal annealing time on value of parameter  $\gamma$  for  $a/L=1/2$  and  $\varepsilon = \xi = 0$

$$U = \frac{1}{L_x L_y L_z} \int_0^{L_x} \int_0^{L_y} \int_0^{L_z} [C(x, y, z, \Theta) - \psi(x, y, z)] dz dy dx. \tag{12}$$

Dependences of optimal values of annealing time are presented on Figs. 4. It is known, that standard step of manufactured ion-doped structures is annealing of radiation defects. In the ideal case after finishing the annealing dopant achieves interface between layers of heterostructure. If the dopant has no enough time to achieve the interface, it is practically to anneal the



dopant additionally. The Fig. 4b shows just the dependences of optimal values of additional annealing time. Necessity to anneal radiation defects leads to smaller values of optimal annealing of implanted dopant in comparison with optimal annealing time of infused dopant.

### Conclusion

In this paper we consider a possibility to increase density of elements in circuit of a voltage doubler based on field-effect heterotransistors. Several conditions to increase the density have been formulated. Analysis of redistribution of dopant with account redistribution of radiation defects (after implantation of ions of dopant) for optimization of the above annealing have been done by using recently introduced analytical approach. The approach gives a possibility to analyze mass and heat transports in a heterostructure without crosslinking of solutions on interfaces between layers of the heterostructure with account nonlinearity of these transports and variation in time of their parameters.

### Reference

1. Volovich G. Modern Electronics. 2006;2:10-17.
2. Kerentsev A, Lanin V. Power Electronics. 2008;1:34.
3. Ageev AO, Belyaev AE, Boltovets NS, Ivanov VN, Konakova RV, Kudrik YaYa, *et al.* Semiconductors. 2009;43(7):897-903.
4. Volokobinskaya NI, Komarov IN, Matioukhina TV, Rechetnikov VI, Rush AA, Falina IV, *et al.* Semiconductors. 2001;35(8):1013-1017.
5. Subramaniam A, Cantley KD, Vogel EM. Active and Passive Electronic Components, 2013. ID 525017.
6. Ong KK, Pey KL, Lee PS, Wee ATS, Wang XC, Chong YF. Appl. Phys. Lett. 2006;89(17):172111-172114.
7. Wang HT, Tan LS, Chor EF. J Appl. Phys. 2006;98(9):094901-094905.
8. Yu V Bykov, Yermeev AG, Zharova NA, Plotnikov IV, Rybakov KI, Drozdov MN, *et al.* Radiophysics and Quantum Electronics. 2003;43(3):836-843.
9. Kozlivsky VV. Modification of semiconductors by proton beams (Nauka, Sant-Peterburg in Russian, 2003).
10. Vinetskiy VL, Kholodar GA. Radiative physics of semiconductors. Naukova Dumka, Kiev in Russian, 1979.
11. Jomehei MG, Sheikhaei S, Fotowat-Ahmady A, Forouzandeh B. Analog Integr. Circ. Sig. Process. 2018;96:21-38.
12. Yu Z Gotra. Technology of microelectronic devices, Radio and communication, Moscow, 1991.
13. Fahey PM, Griffin PB, Plummer JD. Rev. Mod. Phys. 1989;61(2):289-388.
14. Pankratov EL, Bulaeva EA. Int. J Nanoscience. 2012;11(5):1250028-1-1250028-8.
15. Pankratov EL, Bulaeva EA. Reviews in Theoretical Science. 2015;3(2):177-215.
16. Tikhonov AN, Samarskii AA. The mathematical physics equations. Moscow, Nauka, in Russian, 1972.
17. Carslaw HS, Jaeger JC. Conduction of heat in solids. Oxford University Press, 1964.
18. Pankratov EL, Bulaeva EA. Int. J Comp. Sci. Appl. 2015;5(4):1-18.
19. Pankratov EL, Bulaeva EA. Nano Science and Nano Technology: An Indian Journal. 2015;9(4):43-60.
20. Pankratov EL, Bulaeva EA. Int. J Mod. Phys. B. 2015;29(5):1550023-1-1550023-12.
21. Pankratov EL, Bulaeva EA. J Comp. Theor. Nanoscience. 2014;11(1):91-101.

### Appendix

Equations for the functions  $\tilde{I}_{ijk}(\chi, \eta, \phi, \vartheta)$  and  $\tilde{V}_{ijk}(\chi, \eta, \phi, \vartheta)$ ,  $i \geq 0, j \geq 0, k \geq 0$  and conditions for them

$$\begin{aligned} \frac{\partial \tilde{I}_{000}(\chi, \eta, \phi, \vartheta)}{\partial \vartheta} &= \\ &= \sqrt{\frac{D_{0I}}{D_{0V}}} \frac{\partial^2 \tilde{I}_{000}(\chi, \eta, \phi, \vartheta)}{\partial \chi^2} + \sqrt{\frac{D_{0I}}{D_{0V}}} \frac{\partial^2 \tilde{I}_{000}(\chi, \eta, \phi, \vartheta)}{\partial \eta^2} + \sqrt{\frac{D_{0I}}{D_{0V}}} \frac{\partial^2 \tilde{I}_{000}(\chi, \eta, \phi, \vartheta)}{\partial \phi^2} \\ \frac{\partial \tilde{V}_{000}(\chi, \eta, \phi, \vartheta)}{\partial \vartheta} &= \\ &= \sqrt{\frac{D_{0V}}{D_{0I}}} \frac{\partial^2 \tilde{V}_{000}(\chi, \eta, \phi, \vartheta)}{\partial \chi^2} + \sqrt{\frac{D_{0V}}{D_{0I}}} \frac{\partial^2 \tilde{V}_{000}(\chi, \eta, \phi, \vartheta)}{\partial \eta^2} + \sqrt{\frac{D_{0V}}{D_{0I}}} \frac{\partial^2 \tilde{V}_{000}(\chi, \eta, \phi, \vartheta)}{\partial \phi^2}; \end{aligned}$$

$$\begin{aligned}
\frac{\partial \tilde{I}_{i00}(\chi, \vartheta)}{\partial \vartheta} &= \sqrt{\frac{D_{0I}}{D_{0V}}} \left[ \frac{\partial^2 \tilde{I}_{i00}(\chi, \eta, \phi, \vartheta)}{\partial \chi^2} + \frac{\partial^2 \tilde{I}_{i00}(\chi, \eta, \phi, \vartheta)}{\partial \eta^2} + \frac{\partial^2 \tilde{I}_{i00}(\chi, \eta, \phi, \vartheta)}{\partial \phi^2} \right] + \\
&+ \sqrt{\frac{D_{0I}}{D_{0V}}} \frac{\partial}{\partial \chi} \left[ g_I(\chi, \eta, \phi, T) \frac{\partial \tilde{I}_{i-100}(\chi, \eta, \phi, \vartheta)}{\partial \chi} \right] + \sqrt{\frac{D_{0I}}{D_{0V}}} \frac{\partial}{\partial \eta} \left[ g_I(\chi, \eta, \phi, T) \times \right. \\
&\times \left. \frac{\partial \tilde{I}_{i-100}(\chi, \eta, \phi, \vartheta)}{\partial \eta} \right] + \sqrt{\frac{D_{0I}}{D_{0V}}} \frac{\partial}{\partial \phi} \left[ g_I(\chi, \eta, \phi, T) \frac{\partial \tilde{I}_{i-100}(\chi, \eta, \phi, \vartheta)}{\partial \phi} \right], i \geq 1, \\
\frac{\partial \tilde{V}_{i00}(\chi, \vartheta)}{\partial \vartheta} &= \sqrt{\frac{D_{0V}}{D_{0I}}} \left[ \frac{\partial^2 \tilde{V}_{i00}(\chi, \eta, \phi, \vartheta)}{\partial \chi^2} + \frac{\partial^2 \tilde{V}_{i00}(\chi, \eta, \phi, \vartheta)}{\partial \eta^2} + \frac{\partial^2 \tilde{V}_{i00}(\chi, \eta, \phi, \vartheta)}{\partial \phi^2} \right] + \\
&+ \sqrt{\frac{D_{0V}}{D_{0I}}} \frac{\partial}{\partial \chi} \left[ g_V(\chi, \eta, \phi, T) \frac{\partial \tilde{V}_{i-100}(\chi, \eta, \phi, \vartheta)}{\partial \chi} \right] + \sqrt{\frac{D_{0V}}{D_{0I}}} \frac{\partial}{\partial \eta} \left[ g_V(\chi, \eta, \phi, T) \times \right. \\
&\times \left. \frac{\partial \tilde{V}_{i-100}(\chi, \eta, \phi, \vartheta)}{\partial \eta} \right] + \sqrt{\frac{D_{0V}}{D_{0I}}} \frac{\partial}{\partial \phi} \left[ g_V(\chi, \eta, \phi, T) \frac{\partial \tilde{V}_{i-100}(\chi, \eta, \phi, \vartheta)}{\partial \phi} \right], i \geq 1; \\
\frac{\partial \tilde{I}_{010}(\chi, \eta, \phi, \vartheta)}{\partial \vartheta} &= \sqrt{\frac{D_{0I}}{D_{0V}}} \left[ \frac{\partial^2 \tilde{I}_{010}(\chi, \eta, \phi, \vartheta)}{\partial \chi^2} + \frac{\partial^2 \tilde{I}_{010}(\chi, \eta, \phi, \vartheta)}{\partial \eta^2} + \frac{\partial^2 \tilde{I}_{010}(\chi, \eta, \phi, \vartheta)}{\partial \phi^2} \right] - \\
&- [1 + \varepsilon_{I,V} g_{I,V}(\chi, \eta, \phi, T)] \tilde{I}_{000}(\chi, \eta, \phi, \vartheta) \tilde{V}_{000}(\chi, \eta, \phi, \vartheta) \\
\frac{\partial \tilde{V}_{010}(\chi, \eta, \phi, \vartheta)}{\partial \vartheta} &= \sqrt{\frac{D_{0V}}{D_{0I}}} \left[ \frac{\partial^2 \tilde{V}_{010}(\chi, \eta, \phi, \vartheta)}{\partial \chi^2} + \frac{\partial^2 \tilde{V}_{010}(\chi, \eta, \phi, \vartheta)}{\partial \eta^2} + \frac{\partial^2 \tilde{V}_{010}(\chi, \eta, \phi, \vartheta)}{\partial \phi^2} \right] - \\
&- [1 + \varepsilon_{I,V} g_{I,V}(\chi, \eta, \phi, T)] \tilde{I}_{000}(\chi, \eta, \phi, \vartheta) \tilde{V}_{000}(\chi, \eta, \phi, \vartheta); \\
\frac{\partial \tilde{I}_{020}(\chi, \eta, \phi, \vartheta)}{\partial \vartheta} &= \sqrt{\frac{D_{0I}}{D_{0V}}} \left[ \frac{\partial^2 \tilde{I}_{020}(\chi, \eta, \phi, \vartheta)}{\partial \chi^2} + \frac{\partial^2 \tilde{I}_{020}(\chi, \eta, \phi, \vartheta)}{\partial \eta^2} + \frac{\partial^2 \tilde{I}_{020}(\chi, \eta, \phi, \vartheta)}{\partial \phi^2} \right] - \\
&- [1 + \varepsilon_{I,V} g_{I,V}(\chi, \eta, \phi, T)] [\tilde{I}_{010}(\chi, \eta, \phi, \vartheta) \tilde{V}_{000}(\chi, \eta, \phi, \vartheta) + \tilde{I}_{000}(\chi, \eta, \phi, \vartheta) \tilde{V}_{010}(\chi, \eta, \phi, \vartheta)] \\
\frac{\partial \tilde{V}_{020}(\chi, \eta, \phi, \vartheta)}{\partial \vartheta} &= \sqrt{\frac{D_{0I}}{D_{0V}}} \left[ \frac{\partial^2 \tilde{V}_{020}(\chi, \eta, \phi, \vartheta)}{\partial \chi^2} + \frac{\partial^2 \tilde{V}_{020}(\chi, \eta, \phi, \vartheta)}{\partial \eta^2} + \frac{\partial^2 \tilde{V}_{020}(\chi, \eta, \phi, \vartheta)}{\partial \phi^2} \right] - \\
&- [1 + \varepsilon_{I,V} g_{I,V}(\chi, \eta, \phi, T)] [\tilde{I}_{010}(\chi, \eta, \phi, \vartheta) \tilde{V}_{000}(\chi, \eta, \phi, \vartheta) + \tilde{I}_{000}(\chi, \eta, \phi, \vartheta) \tilde{V}_{010}(\chi, \eta, \phi, \vartheta)]; \\
\frac{\partial \tilde{I}_{001}(\chi, \eta, \phi, \vartheta)}{\partial \vartheta} &= \sqrt{\frac{D_{0I}}{D_{0V}}} \left[ \frac{\partial^2 \tilde{I}_{001}(\chi, \eta, \phi, \vartheta)}{\partial \chi^2} + \frac{\partial^2 \tilde{I}_{001}(\chi, \eta, \phi, \vartheta)}{\partial \eta^2} + \frac{\partial^2 \tilde{I}_{001}(\chi, \eta, \phi, \vartheta)}{\partial \phi^2} \right] - \\
&- [1 + \varepsilon_{I,I} g_{I,I}(\chi, \eta, \phi, T)] \tilde{I}_{000}^2(\chi, \eta, \phi, \vartheta)
\end{aligned}$$

$$\begin{aligned}
\frac{\partial \tilde{V}_{001}(\chi, \eta, \phi, \vartheta)}{\partial \vartheta} &= \sqrt{\frac{D_{0V}}{D_{0I}}} \left[ \frac{\partial^2 \tilde{V}_{001}(\chi, \eta, \phi, \vartheta)}{\partial \chi^2} + \frac{\partial^2 \tilde{V}_{001}(\chi, \eta, \phi, \vartheta)}{\partial \eta^2} + \frac{\partial^2 \tilde{V}_{001}(\chi, \eta, \phi, \vartheta)}{\partial \phi^2} \right] - \\
&- [1 + \varepsilon_{I,I} g_{I,I}(\chi, \eta, \phi, T)] \tilde{V}_{000}^2(\chi, \eta, \phi, \vartheta); \\
\frac{\partial \tilde{I}_{110}(\chi, \eta, \phi, \vartheta)}{\partial \vartheta} &= \sqrt{\frac{D_{0I}}{D_{0V}}} \left[ \frac{\partial^2 \tilde{I}_{110}(\chi, \eta, \phi, \vartheta)}{\partial \chi^2} + \frac{\partial^2 \tilde{I}_{110}(\chi, \eta, \phi, \vartheta)}{\partial \eta^2} + \frac{\partial^2 \tilde{I}_{110}(\chi, \eta, \phi, \vartheta)}{\partial \phi^2} \right] + \\
&+ \sqrt{\frac{D_{0I}}{D_{0V}}} \left\{ \frac{\partial}{\partial \chi} \left[ g_I(\chi, \eta, \phi, T) \frac{\partial \tilde{I}_{010}(\chi, \eta, \phi, \vartheta)}{\partial \chi} \right] + \frac{\partial}{\partial \eta} \left[ g_I(\chi, \eta, \phi, T) \frac{\partial \tilde{I}_{010}(\chi, \eta, \phi, \vartheta)}{\partial \eta} \right] + \right. \\
&+ \left. \frac{\partial}{\partial \phi} \left[ g_I(\chi, \eta, \phi, T) \frac{\partial \tilde{I}_{010}(\chi, \eta, \phi, \vartheta)}{\partial \phi} \right] \right\} - [1 + \varepsilon_{I,I} g_{I,I}(\chi, \eta, \phi, T)] [\tilde{I}_{100}(\chi, \eta, \phi, \vartheta) \times \\
&\times \tilde{V}_{000}(\chi, \eta, \phi, \vartheta) + \tilde{I}_{000}(\chi, \eta, \phi, \vartheta) \tilde{V}_{100}(\chi, \eta, \phi, \vartheta)] \\
\frac{\partial \tilde{V}_{110}(\chi, \eta, \phi, \vartheta)}{\partial \vartheta} &= \sqrt{\frac{D_{0V}}{D_{0I}}} \left[ \frac{\partial^2 \tilde{V}_{110}(\chi, \eta, \phi, \vartheta)}{\partial \chi^2} + \frac{\partial^2 \tilde{V}_{110}(\chi, \eta, \phi, \vartheta)}{\partial \eta^2} + \frac{\partial^2 \tilde{V}_{110}(\chi, \eta, \phi, \vartheta)}{\partial \phi^2} \right] + \\
&+ \sqrt{\frac{D_{0V}}{D_{0I}}} \left\{ \frac{\partial}{\partial \chi} \left[ g_V(\chi, \eta, \phi, T) \frac{\partial \tilde{V}_{010}(\chi, \eta, \phi, \vartheta)}{\partial \chi} \right] + \frac{\partial}{\partial \eta} \left[ g_V(\chi, \eta, \phi, T) \frac{\partial \tilde{V}_{010}(\chi, \eta, \phi, \vartheta)}{\partial \eta} \right] + \right. \\
&+ \left. \frac{\partial}{\partial \phi} \left[ g_V(\chi, \eta, \phi, T) \frac{\partial \tilde{V}_{010}(\chi, \eta, \phi, \vartheta)}{\partial \phi} \right] \right\} - [1 + \varepsilon_{V,V} g_{V,V}(\chi, \eta, \phi, T)] [\tilde{V}_{100}(\chi, \eta, \phi, \vartheta) \times \\
&\times \tilde{I}_{000}(\chi, \eta, \phi, \vartheta) + \tilde{V}_{000}(\chi, \eta, \phi, \vartheta) \tilde{I}_{100}(\chi, \eta, \phi, \vartheta)]; \\
\frac{\partial \tilde{I}_{002}(\chi, \eta, \phi, \vartheta)}{\partial \vartheta} &= \sqrt{\frac{D_{0I}}{D_{0V}}} \left[ \frac{\partial^2 \tilde{I}_{002}(\chi, \eta, \phi, \vartheta)}{\partial \chi^2} + \frac{\partial^2 \tilde{I}_{002}(\chi, \eta, \phi, \vartheta)}{\partial \eta^2} + \frac{\partial^2 \tilde{I}_{002}(\chi, \eta, \phi, \vartheta)}{\partial \phi^2} \right] - \\
&- [1 + \varepsilon_{I,I} g_{I,I}(\chi, \eta, \phi, T)] \tilde{I}_{001}(\chi, \eta, \phi, \vartheta) \tilde{I}_{000}(\chi, \eta, \phi, \vartheta) \\
\frac{\partial \tilde{V}_{002}(\chi, \eta, \phi, \vartheta)}{\partial \vartheta} &= \sqrt{\frac{D_{0V}}{D_{0I}}} \left[ \frac{\partial^2 \tilde{V}_{002}(\chi, \eta, \phi, \vartheta)}{\partial \chi^2} + \frac{\partial^2 \tilde{V}_{002}(\chi, \eta, \phi, \vartheta)}{\partial \eta^2} + \frac{\partial^2 \tilde{V}_{002}(\chi, \eta, \phi, \vartheta)}{\partial \phi^2} \right] - \\
&- [1 + \varepsilon_{V,V} g_{V,V}(\chi, \eta, \phi, E)] \tilde{V}_{001}(\chi, \eta, \phi, \vartheta) \tilde{V}_{000}(\chi, \eta, \phi, \vartheta); \\
\frac{\partial \tilde{I}_{101}(\chi, \eta, \phi, \vartheta)}{\partial \vartheta} &= \sqrt{\frac{D_{0I}}{D_{0V}}} \left[ \frac{\partial^2 \tilde{I}_{101}(\chi, \eta, \phi, \vartheta)}{\partial \chi^2} + \frac{\partial^2 \tilde{I}_{101}(\chi, \eta, \phi, \vartheta)}{\partial \eta^2} + \frac{\partial^2 \tilde{I}_{101}(\chi, \eta, \phi, \vartheta)}{\partial \phi^2} \right] +
\end{aligned}$$

$$+ \sqrt{\frac{D_{0I}}{D_{0V}}} \left\{ \frac{\partial}{\partial \chi} \left[ g_I(\chi, \eta, \phi, T) \frac{\partial \tilde{I}_{001}(\chi, \eta, \phi, \vartheta)}{\partial \chi} \right] + \frac{\partial}{\partial \eta} \left[ g_I(\chi, \eta, \phi, T) \frac{\partial \tilde{I}_{001}(\chi, \eta, \phi, \vartheta)}{\partial \eta} \right] + \right. \\ \left. + \frac{\partial}{\partial \phi} \left[ g_I(\chi, \eta, \phi, T) \frac{\partial \tilde{I}_{001}(\chi, \eta, \phi, \vartheta)}{\partial \phi} \right] \right\} - [1 + \varepsilon_I g_I(\chi, \eta, \phi, T)] \tilde{I}_{100}(\chi, \eta, \phi, \vartheta) \tilde{V}_{000}(\chi, \eta, \phi, \vartheta)$$

$$\frac{\partial \tilde{V}_{101}(\chi, \eta, \phi, \vartheta)}{\partial \vartheta} = \sqrt{\frac{D_{0V}}{D_{0I}}} \left[ \frac{\partial^2 \tilde{V}_{101}(\chi, \eta, \phi, \vartheta)}{\partial \chi^2} + \frac{\partial^2 \tilde{V}_{101}(\chi, \eta, \phi, \vartheta)}{\partial \eta^2} + \frac{\partial^2 \tilde{V}_{101}(\chi, \eta, \phi, \vartheta)}{\partial \phi^2} \right] + \\ + \sqrt{\frac{D_{0V}}{D_{0I}}} \left\{ \frac{\partial}{\partial \chi} \left[ g_V(\chi, \eta, \phi, T) \frac{\partial \tilde{V}_{001}(\chi, \eta, \phi, \vartheta)}{\partial \chi} \right] + \frac{\partial}{\partial \eta} \left[ g_V(\chi, \eta, \phi, T) \frac{\partial \tilde{V}_{001}(\chi, \eta, \phi, \vartheta)}{\partial \eta} \right] + \right. \\ \left. + \frac{\partial}{\partial \phi} \left[ g_V(\chi, \eta, \phi, T) \frac{\partial \tilde{V}_{001}(\chi, \eta, \phi, \vartheta)}{\partial \phi} \right] \right\} - [1 + \varepsilon_V g_V(\chi, \eta, \phi, T)] \tilde{I}_{000}(\chi, \eta, \phi, \vartheta) \tilde{V}_{100}(\chi, \eta, \phi, \vartheta);$$

$$\frac{\partial \tilde{I}_{011}(\chi, \eta, \phi, \vartheta)}{\partial \vartheta} = \sqrt{\frac{D_{0I}}{D_{0V}}} \left[ \frac{\partial^2 \tilde{I}_{011}(\chi, \eta, \phi, \vartheta)}{\partial \chi^2} + \frac{\partial^2 \tilde{I}_{011}(\chi, \eta, \phi, \vartheta)}{\partial \eta^2} + \frac{\partial^2 \tilde{I}_{011}(\chi, \eta, \phi, \vartheta)}{\partial \phi^2} \right] - \\ - [1 + \varepsilon_{I,I} g_{I,I}(\chi, \eta, \phi, T)] \tilde{I}_{000}(\chi, \eta, \phi, \vartheta) \tilde{I}_{010}(\chi, \eta, \phi, \vartheta) - [1 + \varepsilon_{I,V} g_{I,V}(\chi, \eta, \phi, T)] \times \\ \times \tilde{I}_{001}(\chi, \eta, \phi, \vartheta) \tilde{V}_{000}(\chi, \eta, \phi, \vartheta)$$

$$\frac{\partial \tilde{V}_{011}(\chi, \eta, \phi, \vartheta)}{\partial \vartheta} = \sqrt{\frac{D_{0V}}{D_{0I}}} \left[ \frac{\partial^2 \tilde{V}_{011}(\chi, \eta, \phi, \vartheta)}{\partial \chi^2} + \frac{\partial^2 \tilde{V}_{011}(\chi, \eta, \phi, \vartheta)}{\partial \eta^2} + \frac{\partial^2 \tilde{V}_{011}(\chi, \eta, \phi, \vartheta)}{\partial \phi^2} \right] - \\ - [1 + \varepsilon_{V,V} g_{V,V}(\chi, \eta, \phi, T)] \tilde{V}_{000}(\chi, \eta, \phi, \vartheta) \tilde{V}_{010}(\chi, \eta, \phi, \vartheta) - [1 + \varepsilon_{I,V} g_{I,V}(\chi, \eta, \phi, T)] \times \\ \times \tilde{I}_{000}(\chi, \eta, \phi, \vartheta) \tilde{V}_{001}(\chi, \eta, \phi, \vartheta);$$

$$\left. \frac{\partial \tilde{\rho}_{ijk}(\chi, \eta, \phi, \vartheta)}{\partial \chi} \right|_{\chi=0} = 0, \left. \frac{\partial \tilde{\rho}_{ijk}(\chi, \eta, \phi, \vartheta)}{\partial \chi} \right|_{\chi=1} = 0, \left. \frac{\partial \tilde{\rho}_{ijk}(\chi, \eta, \phi, \vartheta)}{\partial \eta} \right|_{\eta=0} = 0, \left. \frac{\partial \tilde{\rho}_{ijk}(\chi, \eta, \phi, \vartheta)}{\partial \eta} \right|_{\eta=1} = 0,$$

$$\left. \frac{\partial \tilde{\rho}_{ijk}(\chi, \eta, \phi, \vartheta)}{\partial \phi} \right|_{\phi=0} = 0, \left. \frac{\partial \tilde{\rho}_{ijk}(\chi, \eta, \phi, \vartheta)}{\partial \phi} \right|_{\phi=1} = 0 \quad (i \geq 0, j \geq 0, k \geq 0);$$

$$\tilde{\rho}_{000}(\chi, \eta, \phi, 0) = f_\rho(\chi, \eta, \phi) / \rho^*, \quad \tilde{\rho}_{ijk}(\chi, \eta, \phi, 0) = 0 \quad (i \geq 1, j \geq 1, k \geq 1).$$

Solutions of these equations with account boundary and initial conditions could be written as

$$\tilde{\rho}_{000}(\chi, \eta, \phi, \vartheta) = \frac{1}{L} + \frac{2}{L} \sum_{n=1}^{\infty} F_{n\rho} c(\chi) c(\eta) c(\phi) e_{n\rho}(\vartheta),$$

Where

$$F_{n\rho} = \frac{1}{\rho^*} \int_0^1 \cos(\pi n u) \int_0^1 \cos(\pi n v) \int_0^1 \cos(\pi n w) f_{n\rho}(u, v, w) d w d v d u, c_n(\chi) = \cos(\pi n \chi),$$

$$e_{nI}(\vartheta) = \exp(-\pi^2 n^2 \vartheta \sqrt{D_{0V}/D_{0I}}), e_{nV}(\vartheta) = \exp(-\pi^2 n^2 \vartheta \sqrt{D_{0I}/D_{0V}});$$

$$\begin{aligned} \tilde{I}_{i00}(\chi, \eta, \phi, \vartheta) = & -2\pi \sqrt{\frac{D_{0I}}{D_{0V}}} \sum_{n=1}^{\infty} n c_n(\chi) c(\eta) c(\phi) e_{nI}(\vartheta) \int_0^{\vartheta} e_{nI}(-\tau) \int_0^1 s_n(u) \int_0^1 c_n(v) \int_0^1 g_I(u, v, w, T) \times \\ & \times c_n(w) \frac{\partial \tilde{I}_{i-100}(u, v, w, \tau)}{\partial u} d w d v d u d \tau - 2 \sqrt{\frac{D_{0I}}{D_{0V}}} \sum_{n=1}^{\infty} n c_n(\chi) c(\eta) c(\phi) e_{nI}(\vartheta) \int_0^{\vartheta} e_{nI}(-\tau) \int_0^1 c_n(u) \times \\ & \times \pi \int_0^1 s_n(v) \int_0^1 c_n(w) g_I(u, v, w, T) \frac{\partial \tilde{I}_{i-100}(u, v, w, \tau)}{\partial v} d w d v d u d \tau - 2\pi \sqrt{\frac{D_{0I}}{D_{0V}}} \sum_{n=1}^{\infty} n c_n(\chi) c(\eta) c(\phi) \times \\ & \times e_{nI}(\vartheta) \int_0^{\vartheta} e_{nI}(-\tau) \int_0^1 c_n(u) \int_0^1 c_n(v) \int_0^1 s_n(w) g_I(u, v, w, T) \frac{\partial \tilde{I}_{i-100}(u, v, w, \tau)}{\partial w} d w d v d u d \tau, i \geq 1, \end{aligned}$$

$$\begin{aligned} \tilde{V}_{i00}(\chi, \eta, \phi, \vartheta) = & -2\pi \sqrt{\frac{D_{0V}}{D_{0I}}} \sum_{n=1}^{\infty} n c_n(\chi) c(\eta) c(\phi) e_{nV}(\vartheta) \int_0^{\vartheta} e_{nV}(-\tau) \int_0^1 s_n(u) \int_0^1 c_n(v) \int_0^1 g_V(u, v, w, T) \times \\ & \times c_n(w) \frac{\partial \tilde{V}_{i-100}(u, \tau)}{\partial u} d w d v d u d \tau - \sqrt{\frac{D_{0V}}{D_{0I}}} \sum_{n=1}^{\infty} n c_n(\chi) c(\eta) c(\phi) e_{nV}(\vartheta) \int_0^{\vartheta} e_{nV}(-\tau) \int_0^1 c_n(u) \int_0^1 s_n(v) \times \\ & \times 2\pi \int_0^1 c_n(w) g_V(u, v, w, T) \frac{\partial \tilde{V}_{i-100}(u, \tau)}{\partial v} d w d v d u d \tau - 2\pi \sqrt{\frac{D_{0V}}{D_{0I}}} \sum_{n=1}^{\infty} n c_n(\chi) c(\eta) c(\phi) e_{nV}(\vartheta) \times \\ & \times \int_0^{\vartheta} e_{nV}(-\tau) \int_0^1 c_n(u) \int_0^1 c_n(v) \int_0^1 s_n(w) g_V(u, v, w, T) \frac{\partial \tilde{V}_{i-100}(u, \tau)}{\partial w} d w d v d u d \tau, i \geq 1, \end{aligned}$$

where  $s_n(\chi) = \sin(\pi n \chi)$ ;

$$\begin{aligned} \tilde{\rho}_{010}(\chi, \eta, \phi, \vartheta) = & -2 \sum_{n=1}^{\infty} c_n(\chi) c_n(\eta) c_n(\phi) e_{n\rho}(\vartheta) \int_0^{\vartheta} e_{n\rho}(-\tau) \int_0^1 c_n(u) \int_0^1 c_n(v) \int_0^1 c_n(w) \times \\ & \times [1 + \varepsilon_{I,V} g_{I,V}(u, v, w, T)] \tilde{I}_{000}(u, v, w, \tau) \tilde{V}_{000}(u, v, w, \tau) d w d v d u d \tau; \end{aligned}$$

$$\begin{aligned} \tilde{\rho}_{020}(\chi, \eta, \phi, \vartheta) = & -2 \sqrt{\frac{D_{0I}}{D_{0V}}} \sum_{n=1}^{\infty} c_n(\chi) c_n(\eta) c_n(\phi) e_{n\rho}(\vartheta) \int_0^{\vartheta} e_{n\rho}(-\tau) \int_0^1 c_n(u) \int_0^1 c_n(v) \int_0^1 c_n(w) \times \\ & \times [\tilde{I}_{010}(u, v, w, \tau) \tilde{V}_{000}(u, v, w, \tau) + \tilde{I}_{000}(u, v, w, \tau) \tilde{V}_{010}(u, v, w, \tau)] \times \\ & \times [1 + \varepsilon_{I,V} g_{I,V}(u, v, w, T)] d w d v d u d \tau; \end{aligned}$$

$$\begin{aligned}
 \tilde{\rho}_{001}(\chi, \eta, \phi, \vartheta) &= -2 \sum_{n=1}^{\infty} c_n(\chi) c_n(\eta) c_n(\phi) e_{n\rho}(\vartheta) \int_0^{\vartheta} e_{n\rho}(-\tau) \int_0^1 c_n(u) \int_0^1 c_n(v) \int_0^1 c_n(w) \times \\
 &\times [1 + \varepsilon_{\rho, \rho} g_{\rho, \rho}(u, v, w, T)] \tilde{\rho}_{000}^2(u, v, w, \tau) d w d v d u d \tau; \\
 \tilde{\rho}_{002}(\chi, \eta, \phi, \vartheta) &= -2 \sum_{n=1}^{\infty} c_n(\chi) c_n(\eta) c_n(\phi) e_{n\rho}(\vartheta) \int_0^{\vartheta} e_{n\rho}(-\tau) \int_0^1 c_n(u) \int_0^1 c_n(v) \int_0^1 c_n(w) \times \\
 &\times [1 + \varepsilon_{\rho, \rho} g_{\rho, \rho}(u, v, w, T)] \tilde{\rho}_{001}(u, v, w, \tau) \tilde{\rho}_{000}(u, v, w, \tau) d w d v d u d \tau; \\
 \tilde{I}_{110}(\chi, \eta, \phi, \vartheta) &= -2\pi \sqrt{\frac{D_{0I}}{D_{0V}}} \sum_{n=1}^{\infty} n c_n(\chi) c_n(\eta) c_n(\phi) e_{nI}(\vartheta) \int_0^{\vartheta} e_{nI}(-\tau) \int_0^1 s_n(u) \int_0^1 c_n(v) \int_0^1 c_n(u) \times \\
 &\times g_I(u, v, w, T) \frac{\partial \tilde{I}_{i-100}(u, v, w, \tau)}{\partial u} d w d v d u d \tau - 2\pi \sqrt{\frac{D_{0I}}{D_{0V}}} \sum_{n=1}^{\infty} n c_n(\chi) c_n(\eta) c_n(\phi) e_{nI}(\vartheta) \times \\
 &\times \int_0^{\vartheta} e_{nI}(-\tau) \int_0^1 c_n(u) \int_0^1 s_n(v) \int_0^1 c_n(u) g_I(u, v, w, T) \frac{\partial \tilde{I}_{i-100}(u, v, w, \tau)}{\partial v} d w d v d u d \tau - 2\pi \sqrt{\frac{D_{0I}}{D_{0V}}} \times \\
 &\times \sum_{n=1}^{\infty} n e_{nI}(\vartheta) \int_0^{\vartheta} e_{nI}(-\tau) \int_0^1 c_n(u) \int_0^1 c_n(v) \int_0^1 s_n(u) g_I(u, v, w, T) \frac{\partial \tilde{I}_{i-100}(u, v, w, \tau)}{\partial w} d w d v d u d \tau \times \\
 &\times c_n(\chi) c_n(\eta) c_n(\phi) - 2 \sum_{n=1}^{\infty} c_n(\chi) e_{nI}(\vartheta) c_n(\eta) c_n(\phi) \int_0^{\vartheta} e_{nI}(-\tau) \int_0^1 c_n(u) \int_0^1 c_n(v) \int_0^1 c_n(v) [1 + \varepsilon_{I, V} \times \\
 &\times g_{I, V}(u, v, w, T)] [\tilde{I}_{100}(u, v, w, \tau) \tilde{V}_{000}(u, v, w, \tau) + \tilde{I}_{000}(u, v, w, \tau) \tilde{V}_{100}(u, v, w, \tau)] d w d v d u d \tau \\
 \tilde{V}_{110}(\chi, \eta, \phi, \vartheta) &= -2\pi \sqrt{\frac{D_{0V}}{D_{0I}}} \sum_{n=1}^{\infty} n c_n(\chi) c_n(\eta) c_n(\phi) e_{nV}(\vartheta) \int_0^{\vartheta} e_{nV}(-\tau) \int_0^1 s_n(u) \int_0^1 c_n(v) \int_0^1 c_n(u) \times \\
 &\times g_V(u, v, w, T) \frac{\partial \tilde{V}_{i-100}(u, v, w, \tau)}{\partial u} d w d v d u d \tau - 2\pi \sqrt{\frac{D_{0V}}{D_{0I}}} \sum_{n=1}^{\infty} n c_n(\chi) c_n(\eta) c_n(\phi) e_{nV}(\vartheta) \times \\
 &\times \int_0^{\vartheta} e_{nV}(-\tau) \int_0^1 c_n(u) \int_0^1 s_n(v) \int_0^1 c_n(u) g_V(u, v, w, T) \frac{\partial \tilde{V}_{i-100}(u, v, w, \tau)}{\partial v} d w d v d u d \tau - 2\pi \sqrt{\frac{D_{0V}}{D_{0I}}} \times \\
 &\times \sum_{n=1}^{\infty} n e_{nV}(\vartheta) \int_0^{\vartheta} e_{nV}(-\tau) \int_0^1 c_n(u) \int_0^1 c_n(v) \int_0^1 s_n(u) g_V(u, v, w, T) \frac{\partial \tilde{V}_{i-100}(u, v, w, \tau)}{\partial w} d w d v d u d \tau \times \\
 &\times c_n(\chi) c_n(\eta) c_n(\phi) - 2 \sum_{n=1}^{\infty} c_n(\chi) e_{nI}(\vartheta) c_n(\eta) c_n(\phi) \int_0^{\vartheta} e_{nV}(-\tau) \int_0^1 c_n(u) \int_0^1 c_n(v) \int_0^1 c_n(v) [1 + \varepsilon_{I, V} \times \\
 &\times g_{I, V}(u, v, w, T)] [\tilde{I}_{100}(u, v, w, \tau) \tilde{V}_{000}(u, v, w, \tau) + \tilde{I}_{000}(u, v, w, \tau) \tilde{V}_{100}(u, v, w, \tau)] d w d v d u d \tau;
 \end{aligned}$$

$$\begin{aligned}
\tilde{I}_{101}(\chi, \eta, \phi, \vartheta) &= -2\pi \sqrt{\frac{D_{0I}}{D_{0V}}} \sum_{n=1}^{\infty} n c_n(\chi) c_n(\eta) c_n(\phi) e_{nI}(\vartheta) \int_0^{\vartheta} e_{nI}(-\tau) \int_0^1 s_n(u) \int_0^1 c_n(v) \int_0^1 c_n(w) \times \\
&\times g_I(u, v, w, T) \frac{\partial \tilde{I}_{001}(u, v, w, \tau)}{\partial u} d w d v d u d \tau - 2\pi \sqrt{\frac{D_{0I}}{D_{0V}}} \sum_{n=1}^{\infty} n c_n(\chi) c_n(\eta) c_n(\phi) e_{nI}(\vartheta) \times \\
&\times \int_0^{\vartheta} e_{nI}(-\tau) \int_0^1 c_n(u) \int_0^1 s_n(v) \int_0^1 c_n(w) g_I(u, v, w, T) \frac{\partial \tilde{I}_{001}(u, v, w, \tau)}{\partial v} d w d v d u d \tau - 2\pi \sqrt{\frac{D_{0I}}{D_{0V}}} \times \\
&\times \sum_{n=1}^{\infty} n e_{nI}(\vartheta) \int_0^{\vartheta} e_{nI}(-\tau) \int_0^1 c_n(u) \int_0^1 c_n(v) \int_0^1 s_n(w) g_I(u, v, w, T) \frac{\partial \tilde{I}_{001}(u, v, w, \tau)}{\partial w} d w d v d u d \tau \times \\
&\times c_n(\chi) c_n(\eta) c_n(\phi) - 2 \sum_{n=1}^{\infty} c_n(\chi) c_n(\eta) c_n(\phi) e_{nI}(\vartheta) \int_0^{\vartheta} e_{nI}(-\tau) \int_0^1 [1 + \varepsilon_{I,V} g_{I,V}(u, v, w, T)] \times \\
&\times c_n(u) \tilde{I}_{100}(u, v, w, \tau) \tilde{V}_{000}(u, v, w, \tau) d w d v d u d \tau \\
\tilde{V}_{101}(\chi, \eta, \phi, \vartheta) &= -2\pi \sqrt{\frac{D_{0V}}{D_{0I}}} \sum_{n=1}^{\infty} n c_n(\chi) c_n(\eta) c_n(\phi) e_{nV}(\vartheta) \int_0^{\vartheta} e_{nV}(-\tau) \int_0^1 s_n(u) \int_0^1 c_n(v) \int_0^1 c_n(w) \times \\
&\times g_V(u, v, w, T) \frac{\partial \tilde{V}_{001}(u, v, w, \tau)}{\partial u} d w d v d u d \tau - 2\pi \sqrt{\frac{D_{0V}}{D_{0I}}} \sum_{n=1}^{\infty} n c_n(\chi) c_n(\eta) c_n(\phi) e_{nV}(\vartheta) \times \\
&\times \int_0^{\vartheta} e_{nV}(-\tau) \int_0^1 c_n(u) \int_0^1 s_n(v) \int_0^1 c_n(w) g_V(u, v, w, T) \frac{\partial \tilde{V}_{001}(u, v, w, \tau)}{\partial v} d w d v d u d \tau - 2\pi \sqrt{\frac{D_{0V}}{D_{0I}}} \times \\
&\times \sum_{n=1}^{\infty} n e_{nV}(\vartheta) \int_0^{\vartheta} e_{nV}(-\tau) \int_0^1 c_n(u) \int_0^1 c_n(v) \int_0^1 s_n(w) g_V(u, v, w, T) \frac{\partial \tilde{V}_{001}(u, v, w, \tau)}{\partial w} d w d v d u d \tau \times \\
&\times c_n(\chi) c_n(\eta) c_n(\phi) - 2 \sum_{n=1}^{\infty} c_n(\chi) c_n(\eta) c_n(\phi) e_{nV}(\vartheta) \int_0^{\vartheta} e_{nV}(-\tau) \int_0^1 c_n(u) \int_0^1 c_n(v) \int_0^1 c_n(w) [1 + \varepsilon_{I,V} \times \\
&\times g_{I,V}(u, v, w, T)] \tilde{I}_{000}(u, v, w, \tau) \tilde{V}_{100}(u, v, w, \tau) d w d v d u d \tau ; \\
\tilde{I}_{011}(\chi, \eta, \phi, \vartheta) &= -2 \sum_{n=1}^{\infty} c_n(\chi) c_n(\eta) c_n(\phi) e_{nI}(\vartheta) \int_0^{\vartheta} e_{nI}(-\tau) \int_0^1 c_n(u) \int_0^1 c_n(v) \int_0^1 c_n(w) \times \\
&\times \{ [1 + \varepsilon_{I,I} g_{I,I}(u, v, w, T)] \tilde{I}_{000}(u, v, w, \tau) \tilde{I}_{010}(u, v, w, \tau) + [1 + \varepsilon_{I,V} g_{I,V}(u, v, w, T)] \times \\
&\times \tilde{I}_{001}(u, v, w, \tau) \tilde{V}_{000}(u, v, w, \tau) \} d w d v d u d \tau \\
\tilde{V}_{011}(\chi, \eta, \phi, \vartheta) &= -2 \sum_{n=1}^{\infty} c_n(\chi) c_n(\eta) c_n(\phi) e_{nV}(\vartheta) \int_0^{\vartheta} e_{nV}(-\tau) \int_0^1 c_n(u) \int_0^1 c_n(v) \int_0^1 c_n(w) \times
\end{aligned}$$

$$\times \left\{ [1 + \varepsilon_{V,V} g_{V,V}(u, v, w, T)] \tilde{V}_{000}(u, v, w, \tau) \tilde{V}_{010}(u, v, w, \tau) + [1 + \varepsilon_{I,V} g_{I,V}(u, v, w, T)] \times \right. \\ \left. \times \tilde{I}_{000}(u, v, w, \tau) \tilde{V}_{001}(u, v, w, \tau) \right\} d w d v d u d \tau.$$

Equations for initial-order approximations of distributions of concentrations of simplest complexes of radiation defects  $\Phi_{\rho 0}(x, y, z, t)$  and corrections for them  $\Phi_{\rho i}(x, y, z, t)$ ,  $i \geq 1$  and boundary and initial conditions for them takes the form

$$\frac{\partial \Phi_{I0}(x, y, z, t)}{\partial t} = D_{0\Phi I} \left[ \frac{\partial^2 \Phi_{I0}(x, y, z, t)}{\partial x^2} + \frac{\partial^2 \Phi_{I0}(x, y, z, t)}{\partial y^2} + \frac{\partial^2 \Phi_{I0}(x, y, z, t)}{\partial z^2} \right] + \\ + k_{I,I}(x, y, z, T) I^2(x, y, z, t) - k_I(x, y, z, T) I(x, y, z, t) \\ \frac{\partial \Phi_{V0}(x, y, z, t)}{\partial t} = D_{0\Phi V} \left[ \frac{\partial^2 \Phi_{V0}(x, y, z, t)}{\partial x^2} + \frac{\partial^2 \Phi_{V0}(x, y, z, t)}{\partial y^2} + \frac{\partial^2 \Phi_{V0}(x, y, z, t)}{\partial z^2} \right] + \\ + k_{V,V}(x, y, z, T) V^2(x, y, z, t) - k_V(x, y, z, T) V(x, y, z, t); \\ \frac{\partial \Phi_{Ii}(x, y, z, t)}{\partial t} = D_{0\Phi I} \left[ \frac{\partial^2 \Phi_{Ii}(x, y, z, t)}{\partial x^2} + \frac{\partial^2 \Phi_{Ii}(x, y, z, t)}{\partial y^2} + \frac{\partial^2 \Phi_{Ii}(x, y, z, t)}{\partial z^2} \right] + \\ + D_{0\Phi I} \left\{ \frac{\partial}{\partial x} \left[ g_{\Phi I}(x, y, z, T) \frac{\partial \Phi_{Ii-1}(x, y, z, t)}{\partial x} \right] + \frac{\partial}{\partial y} \left[ g_{\Phi I}(x, y, z, T) \frac{\partial \Phi_{Ii-1}(x, y, z, t)}{\partial y} \right] + \right. \\ \left. + \frac{\partial}{\partial z} \left[ g_{\Phi I}(x, y, z, T) \frac{\partial \Phi_{Ii-1}(x, y, z, t)}{\partial z} \right] \right\}, i \geq 1, \\ \frac{\partial \Phi_{Vi}(x, y, z, t)}{\partial t} = D_{0\Phi V} \left[ \frac{\partial^2 \Phi_{Vi}(x, y, z, t)}{\partial x^2} + \frac{\partial^2 \Phi_{Vi}(x, y, z, t)}{\partial y^2} + \frac{\partial^2 \Phi_{Vi}(x, y, z, t)}{\partial z^2} \right] + \\ + D_{0\Phi V} \left\{ \frac{\partial}{\partial x} \left[ g_{\Phi V}(x, y, z, T) \frac{\partial \Phi_{Vi-1}(x, y, z, t)}{\partial x} \right] + \frac{\partial}{\partial y} \left[ g_{\Phi V}(x, y, z, T) \frac{\partial \Phi_{Vi-1}(x, y, z, t)}{\partial y} \right] + \right. \\ \left. + \frac{\partial}{\partial z} \left[ g_{\Phi V}(x, y, z, T) \frac{\partial \Phi_{Vi-1}(x, y, z, t)}{\partial z} \right] \right\}, i \geq 1; \\ \frac{\partial \Phi_{\rho i}(x, y, z, t)}{\partial x} \Big|_{x=0} = 0, \frac{\partial \Phi_{\rho i}(x, y, z, t)}{\partial x} \Big|_{x=L_x} = 0, \frac{\partial \Phi_{\rho i}(x, y, z, t)}{\partial y} \Big|_{y=0} = 0, \\ \frac{\partial \Phi_{\rho i}(x, y, z, t)}{\partial y} \Big|_{y=L_y} = 0, \frac{\partial \Phi_{\rho i}(x, y, z, t)}{\partial z} \Big|_{z=0} = 0, \frac{\partial \Phi_{\rho i}(x, y, z, t)}{\partial z} \Big|_{z=L_z} = 0, i \geq 0;$$



$$\Phi_{\rho 0}(x, y, z, 0) = f_{\Phi \rho}(x, y, z), \quad \Phi_{\rho i}(x, y, z, 0) = 0, \quad i \geq 1.$$

Solutions of the above equations could be written as

$$\begin{aligned} \Phi_{\rho 0}(x, y, z, t) &= \frac{1}{L_x L_y L_z} + \frac{2}{L_x L_y L_z} \sum_{n=1}^{\infty} F_{n\Phi \rho} c_n(x) c_n(y) c_n(z) e_{n\Phi \rho}(t) + \frac{2}{L_x L_y L_z} \sum_{n=1}^{\infty} n c_n(x) c_n(y) \times \\ &\times c_n(z) e_{\Phi \rho n}(t) \int_0^t e_{\Phi \rho n}(-\tau) \int_0^{L_x} c_n(u) \int_0^{L_y} c_n(v) \int_0^{L_z} c_n(w) [k_{I,i}(u, v, w, T) I^2(u, v, w, \tau) - \\ &- k_I(u, v, w, T) I(u, v, w, \tau)] d w d v d u d \tau, \end{aligned}$$

Where

$$\begin{aligned} F_{n\Phi \rho} &= \int_0^{L_x} c_n(u) \int_0^{L_y} c_n(v) \int_0^{L_z} c_n(w) f_{\Phi \rho}(u, v, w) d w d v d u, \quad c_n(x) = \cos(\pi n x / L_x), \\ e_{n\Phi \rho}(t) &= \exp \left[ -\pi^2 n^2 D_{0\Phi \rho} t (L_x^{-2} + L_y^{-2} + L_z^{-2}) \right]; \\ \Phi_{\rho i}(x, y, z, t) &= -\frac{2\pi}{L_x L_y L_z} \sum_{n=1}^{\infty} n c_n(x) c_n(y) c_n(z) e_{\Phi \rho n}(t) \int_0^t e_{\Phi \rho n}(-\tau) \int_0^{L_x} s_n(u) \int_0^{L_y} c_n(v) \int_0^{L_z} c_n(w) \times \\ &\times g_{\Phi \rho}(u, v, w, T) \frac{\partial \Phi_{I\rho^{i-1}}(u, v, w, \tau)}{\partial u} d w d v d u d \tau - \frac{2\pi}{L_x L_y L_z} \sum_{n=1}^{\infty} n c_n(x) c_n(y) c_n(z) e_{\Phi \rho n}(t) \times \\ &\times \int_0^t e_{\Phi \rho n}(-\tau) \int_0^{L_x} c_n(u) \int_0^{L_y} s_n(v) \int_0^{L_z} c_n(w) g_{\Phi \rho}(u, v, w, T) \frac{\partial \Phi_{I\rho^{i-1}}(u, v, w, \tau)}{\partial v} d w d v d u d \tau - \frac{2\pi}{L_x L_y} \times \\ &\times \frac{1}{L_z} \sum_{n=1}^{\infty} n c_n(x) c_n(y) c_n(z) e_{\Phi \rho n}(t) \int_0^t e_{\Phi \rho n}(-\tau) \int_0^{L_x} c_n(u) \int_0^{L_y} c_n(v) \int_0^{L_z} s_n(w) \frac{\partial \Phi_{I\rho^{i-1}}(u, v, w, \tau)}{\partial w} \times \\ &\times g_{\Phi \rho}(u, v, w, T) d w d v d u d \tau, \quad i \geq 1, \end{aligned}$$

where  $s_n(x) = \sin(\pi n x / L_x)$ .

Equations for initial-order approximation of dopant concentration  $C_{00}(x, y, z, t)$ , corrections for them  $C_{ij}(x, y, z, t)$  ( $i \geq 1, j \geq 1$ ) and boundary and initial conditions take the form

$$\begin{aligned} \frac{\partial C_{00}(x, y, z, t)}{\partial t} &= D_{0L} \frac{\partial^2 C_{00}(x, y, z, t)}{\partial x^2} + D_{0L} \frac{\partial^2 C_{00}(x, y, z, t)}{\partial y^2} + D_{0L} \frac{\partial^2 C_{00}(x, y, z, t)}{\partial z^2}; \\ \frac{\partial C_{i0}(x, y, z, t)}{\partial t} &= D_{0L} \frac{\partial^2 C_{i0}(x, y, z, t)}{\partial x^2} + D_{0L} \frac{\partial^2 C_{i0}(x, y, z, t)}{\partial y^2} + D_{0L} \frac{\partial^2 C_{i0}(x, y, z, t)}{\partial z^2} + \\ &+ D_{0L} \frac{\partial}{\partial x} \left[ g_L(x, y, z, T) \frac{\partial C_{i-10}(x, y, z, t)}{\partial x} \right] + D_{0L} \frac{\partial}{\partial y} \left[ g_L(x, y, z, T) \frac{\partial C_{i-10}(x, y, z, t)}{\partial y} \right] + \end{aligned}$$

$$\begin{aligned}
& + D_{0L} \frac{\partial}{\partial z} \left[ g_L(x, y, z, T) \frac{\partial C_{i-10}(x, y, z, t)}{\partial z} \right], i \geq 1; \\
\frac{\partial C_{01}(x, y, z, t)}{\partial t} & = D_{0L} \frac{\partial^2 C_{01}(x, y, z, t)}{\partial x^2} + D_{0L} \frac{\partial^2 C_{01}(x, y, z, t)}{\partial y^2} + D_{0L} \frac{\partial^2 C_{01}(x, y, z, t)}{\partial z^2} + \\
& + D_{0L} \frac{\partial}{\partial x} \left[ \frac{C_{00}^\gamma(x, y, z, t)}{P^\gamma(x, y, z, T)} \frac{\partial C_{00}(x, y, z, t)}{\partial x} \right] + D_{0L} \frac{\partial}{\partial y} \left[ \frac{C_{00}^\gamma(x, y, z, t)}{P^\gamma(x, y, z, T)} \frac{\partial C_{00}(x, y, z, t)}{\partial y} \right] + \\
& + D_{0L} \frac{\partial}{\partial z} \left[ \frac{C_{00}^\gamma(x, y, z, t)}{P^\gamma(x, y, z, T)} \frac{\partial C_{00}(x, y, z, t)}{\partial z} \right]; \\
\frac{\partial C_{02}(x, y, z, t)}{\partial t} & = D_{0L} \frac{\partial^2 C_{02}(x, y, z, t)}{\partial x^2} + D_{0L} \frac{\partial^2 C_{02}(x, y, z, t)}{\partial y^2} + D_{0L} \frac{\partial^2 C_{02}(x, y, z, t)}{\partial z^2} + \\
& + \left\{ \frac{\partial}{\partial x} \left[ C_{01}(x, y, z, t) \frac{C_{00}^{\gamma-1}(x, y, z, t)}{P^\gamma(x, y, z, T)} \frac{\partial C_{00}(x, y, z, t)}{\partial x} \right] + \frac{\partial}{\partial y} \left[ C_{01}(x, y, z, t) \frac{C_{00}^{\gamma-1}(x, y, z, t)}{P^\gamma(x, y, z, T)} \times \right. \right. \\
& \times \left. \frac{\partial C_{00}(x, y, z, t)}{\partial y} \right] + \frac{\partial}{\partial z} \left[ C_{01}(x, y, z, t) \frac{C_{00}^{\gamma-1}(x, y, z, t)}{P^\gamma(x, y, z, T)} \frac{\partial C_{00}(x, y, z, t)}{\partial z} \right] \left. \right\} D_{0L} + \\
& + D_{0L} \left\{ \frac{\partial}{\partial x} \left[ \frac{C_{00}^\gamma(x, y, z, t)}{P^\gamma(x, y, z, T)} \frac{\partial C_{01}(x, y, z, t)}{\partial x} \right] + \frac{\partial}{\partial y} \left[ \frac{C_{00}^\gamma(x, y, z, t)}{P^\gamma(x, y, z, T)} \frac{\partial C_{01}(x, y, z, t)}{\partial y} \right] + \right. \\
& \left. + \frac{\partial}{\partial z} \left[ \frac{C_{00}^\gamma(x, y, z, t)}{P^\gamma(x, y, z, T)} \frac{\partial C_{01}(x, y, z, t)}{\partial z} \right] \right\}; \\
\frac{\partial C_{11}(x, y, z, t)}{\partial t} & = D_{0L} \frac{\partial^2 C_{11}(x, y, z, t)}{\partial x^2} + D_{0L} \frac{\partial^2 C_{11}(x, y, z, t)}{\partial y^2} + D_{0L} \frac{\partial^2 C_{11}(x, y, z, t)}{\partial z^2} + \\
& + \left\{ \frac{\partial}{\partial x} \left[ C_{10}(x, y, z, t) \frac{C_{00}^{\gamma-1}(x, y, z, t)}{P^\gamma(x, y, z, T)} \frac{\partial C_{00}(x, y, z, t)}{\partial x} \right] + \frac{\partial}{\partial y} \left[ C_{10}(x, y, z, t) \frac{C_{00}^{\gamma-1}(x, y, z, t)}{P^\gamma(x, y, z, T)} \times \right. \right. \\
& \times \left. \frac{\partial C_{00}(x, y, z, t)}{\partial y} \right] + \frac{\partial}{\partial z} \left[ C_{10}(x, y, z, t) \frac{C_{00}^{\gamma-1}(x, y, z, t)}{P^\gamma(x, y, z, T)} \frac{\partial C_{00}(x, y, z, t)}{\partial z} \right] \left. \right\} D_{0L} + \\
& + D_{0L} \left\{ \frac{\partial}{\partial x} \left[ \frac{C_{00}^\gamma(x, y, z, t)}{P^\gamma(x, y, z, T)} \frac{\partial C_{10}(x, y, z, t)}{\partial x} \right] + \frac{\partial}{\partial y} \left[ \frac{C_{00}^\gamma(x, y, z, t)}{P^\gamma(x, y, z, T)} \frac{\partial C_{10}(x, y, z, t)}{\partial y} \right] + \right.
\end{aligned}$$

$$+ \frac{\partial}{\partial z} \left[ \frac{C_{00}^\gamma(x, y, z, t)}{P^\gamma(x, y, z, T)} \frac{\partial C_{10}(x, y, z, t)}{\partial z} \right] + D_{0L} \left\{ \frac{\partial}{\partial x} \left[ g_L(x, y, z, T) \frac{\partial C_{01}(x, y, z, t)}{\partial x} \right] + \frac{\partial}{\partial y} \left[ g_L(x, y, z, T) \frac{\partial C_{01}(x, y, z, t)}{\partial y} \right] + \frac{\partial}{\partial z} \left[ g_L(x, y, z, T) \frac{\partial C_{01}(x, y, z, t)}{\partial z} \right] \right\};$$

$$\left. \frac{\partial C_{ij}(x, y, z, t)}{\partial x} \right|_{x=0} = 0, \left. \frac{\partial C_{ij}(x, y, z, t)}{\partial x} \right|_{x=L_x} = 0, \left. \frac{\partial C_{ij}(x, y, z, t)}{\partial y} \right|_{y=0} = 0, \left. \frac{\partial C_{ij}(x, y, z, t)}{\partial y} \right|_{y=L_y} = 0, \left. \frac{\partial C_{ij}(x, y, z, t)}{\partial z} \right|_{z=0} = 0, \left. \frac{\partial C_{ij}(x, y, z, t)}{\partial z} \right|_{z=L_z} = 0, i \geq 0, j \geq 0;$$

$$C_{00}(x, y, z, 0) = f_C(x, y, z), C_{ij}(x, y, z, 0) = 0, i \geq 1, j \geq 1.$$

Solutions of the above equations with account boundary and initial conditions could be written as

$$C_{00}(x, y, z, t) = \frac{1}{L_x L_y L_z} + \frac{2}{L_x L_y L_z} \sum_{n=1}^{\infty} F_{nC} c_n(x) c_n(y) c_n(z) e_{nC}(t),$$

Where

$$e_{nC}(t) = \exp \left[ -\pi^2 n^2 D_{0C} t (L_x^{-2} + L_y^{-2} + L_z^{-2}) \right], F_{nC} = \int_0^{L_x} c_n(u) \int_0^{L_y} c_n(v) \int_0^{L_z} f_C(u, v, w) \times c_n(w) dw dv du;$$

$$C_{i0}(x, y, z, t) = -\frac{2\pi}{L_x^2 L_y L_z} \sum_{n=1}^{\infty} n F_{nC} c_n(x) c_n(y) c_n(z) e_{nC}(t) \int_0^t e_{nC}(-\tau) \int_0^{L_x} s_n(u) \int_0^{L_y} c_n(v) \int_0^{L_z} c_n(v) \times g_L(u, v, w, T) \frac{\partial C_{i-10}(u, v, w, \tau)}{\partial u} dw dv du d\tau - \frac{2\pi}{L_x L_y^2 L_z} \sum_{n=1}^{\infty} n F_{nC} c_n(x) c_n(y) c_n(z) e_{nC}(t) \times \int_0^t e_{nC}(-\tau) \int_0^{L_x} c_n(u) \int_0^{L_y} s_n(v) \int_0^{L_z} c_n(v) g_L(u, v, w, T) \frac{\partial C_{i-10}(u, v, w, \tau)}{\partial v} dw dv du d\tau - \frac{2\pi}{L_x L_y L_z^2} \times \sum_{n=1}^{\infty} n e_{nC}(t) \int_0^t e_{nC}(-\tau) \int_0^{L_x} c_n(u) \int_0^{L_y} c_n(v) \int_0^{L_z} s_n(v) g_L(u, v, w, T) \frac{\partial C_{i-10}(u, v, w, \tau)}{\partial w} dw dv du d\tau \times F_{nC} c_n(x) c_n(y) c_n(z), i \geq 1;$$

$$C_{01}(x, y, z, t) = -\frac{2\pi}{L_x^2 L_y L_z} \sum_{n=1}^{\infty} n F_{nC} c_n(x) c_n(y) c_n(z) e_{nC}(t) \int_0^t e_{nC}(-\tau) \int_0^{L_x} s_n(u) \int_0^{L_y} c_n(v) \int_0^{L_z} c_n(w) \times$$

$$\begin{aligned}
& \times \frac{C_{00}^\gamma(u, v, w, \tau)}{P^\gamma(u, v, w, T)} \frac{\partial C_{00}(u, v, w, \tau)}{\partial u} d w d v d u d \tau - \frac{2\pi}{L_x L_y L_z} \sum_{n=1}^{\infty} n F_{nC} c_n(x) c_n(y) c_n(z) e_{nC}(t) \times \\
& \times \int_0^t e_{nC}(-\tau) \int_0^{L_x} c_n(u) \int_0^{L_y} s_n(v) \int_0^{L_z} c_n(w) \frac{C_{00}^\gamma(u, v, w, \tau)}{P^\gamma(u, v, w, T)} \frac{\partial C_{00}(u, v, w, \tau)}{\partial v} d w d v d u d \tau - \frac{2\pi}{L_x L_y L_z} \times \\
& \times \sum_{n=1}^{\infty} n e_{nC}(t) \int_0^t e_{nC}(-\tau) \int_0^{L_x} c_n(u) \int_0^{L_y} c_n(v) \int_0^{L_z} s_n(w) \frac{C_{00}^\gamma(u, v, w, \tau)}{P^\gamma(u, v, w, T)} \frac{\partial C_{00}(u, v, w, \tau)}{\partial w} d w d v d u d \tau \times \\
& \times F_{nC} c_n(x) c_n(y) c_n(z); \\
C_{02}(x, y, z, t) = & -\frac{2\pi}{L_x^2 L_y L_z} \sum_{n=1}^{\infty} n F_{nC} c_n(x) c_n(y) c_n(z) e_{nC}(t) \int_0^t e_{nC}(-\tau) \int_0^{L_x} s_n(u) \int_0^{L_y} c_n(v) \int_0^{L_z} c_n(w) \times \\
& \times C_{01}(u, v, w, \tau) \frac{C_{00}^{\gamma-1}(u, v, w, \tau)}{P^\gamma(u, v, w, T)} \frac{\partial C_{00}(u, v, w, \tau)}{\partial u} d w d v d u d \tau - \frac{2\pi}{L_x L_y^2 L_z} \sum_{n=1}^{\infty} F_{nC} c_n(x) c_n(y) \times \\
& \times n c_n(z) e_{nC}(t) \int_0^t e_{nC}(-\tau) \int_0^{L_x} c_n(u) \int_0^{L_y} s_n(v) \int_0^{L_z} C_{01}(u, v, w, \tau) \frac{C_{00}^{\gamma-1}(u, v, w, \tau)}{P^\gamma(u, v, w, T)} \frac{\partial C_{00}(u, v, w, \tau)}{\partial v} \times \\
& \times c_n(w) d w d v d u d \tau - \frac{2\pi}{L_x L_y L_z^2} \sum_{n=1}^{\infty} n F_{nC} c_n(x) c_n(y) c_n(z) e_{nC}(t) \int_0^t e_{nC}(-\tau) \int_0^{L_x} c_n(u) \int_0^{L_y} c_n(v) \times \\
& \times \int_0^{L_z} s_n(w) C_{01}(u, v, w, \tau) \frac{C_{00}^{\gamma-1}(u, v, w, \tau)}{P^\gamma(u, v, w, T)} \frac{\partial C_{00}(u, v, w, \tau)}{\partial w} d w d v d u d \tau - \frac{2\pi}{L_x^2 L_y L_z} \sum_{n=1}^{\infty} n c_n(x) \times \\
& \times F_{nC} c_n(y) c_n(z) e_{nC}(t) \int_0^t e_{nC}(-\tau) \int_0^{L_x} s_n(u) \int_0^{L_y} c_n(v) \int_0^{L_z} c_n(w) C_{01}(u, v, w, \tau) \frac{\partial C_{00}(u, v, w, \tau)}{\partial u} \times \\
& \times \frac{C_{00}^{\gamma-1}(u, v, w, \tau)}{P^\gamma(u, v, w, T)} d w d v d u d \tau - \frac{2\pi}{L_x L_y^2 L_z} \sum_{n=1}^{\infty} n F_{nC} c_n(x) c_n(y) c_n(z) e_{nC}(t) \int_0^t e_{nC}(-\tau) \int_0^{L_x} c_n(u) \times \\
& \times \int_0^{L_y} s_n(v) \int_0^{L_z} c_n(w) C_{01}(u, v, w, \tau) \frac{C_{00}^{\gamma-1}(u, v, w, \tau)}{P^\gamma(u, v, w, T)} \frac{\partial C_{00}(u, v, w, \tau)}{\partial v} d w d v d u d \tau - \frac{2\pi}{L_x L_y L_z^2} \sum_{n=1}^{\infty} n \times \\
& \times F_{nC} c_n(x) c_n(y) c_n(z) e_{nC}(t) \int_0^t e_{nC}(-\tau) \int_0^{L_x} c_n(u) \int_0^{L_y} c_n(v) \int_0^{L_z} s_n(w) C_{01}(u, v, w, \tau) \frac{C_{00}^{\gamma-1}(u, v, w, \tau)}{P^\gamma(u, v, w, T)} \times \\
& \times \frac{\partial C_{00}(u, v, w, \tau)}{\partial w} d w d v d u d \tau - \frac{2\pi}{L_x^2 L_y L_z} \sum_{n=1}^{\infty} F_{nC} c_n(x) c_n(y) c_n(z) e_{nC}(t) \int_0^t e_{nC}(-\tau) \int_0^{L_x} s_n(u) \times
\end{aligned}$$

$$\begin{aligned}
& \times n \int_0^{L_y} c_n(v) \int_0^{L_z} c_n(w) \frac{C_{00}^\gamma(u, v, w, \tau)}{P^\gamma(u, v, w, T)} \frac{\partial C_{01}(u, v, w, \tau)}{\partial u} d w d v d u d \tau - \frac{2\pi}{L_x L_y^2 L_z} \sum_{n=1}^{\infty} c_n(x) e_{nC}(t) \times \\
& \times F_{nC} c_n(y) \int_0^t e_{nC}(-\tau) \int_0^{L_x} c_n(u) \int_0^{L_y} s_n(v) \int_0^{L_z} c_n(w) \frac{C_{00}^\gamma(u, v, w, \tau)}{P^\gamma(u, v, w, T)} \frac{\partial C_{01}(u, v, w, \tau)}{\partial v} d w d v d u d \tau \times \\
& \times n c_n(z) - \frac{2\pi}{L_x L_y L_z} \sum_{n=1}^{\infty} n F_{nC} c_n(x) c_n(y) c_n(z) e_{nC}(t) \int_0^t e_{nC}(-\tau) \int_0^{L_x} c_n(u) \int_0^{L_y} c_n(v) \int_0^{L_z} s_n(w) \times \\
& \times \frac{C_{00}^\gamma(u, v, w, \tau)}{P^\gamma(u, v, w, T)} \frac{\partial C_{01}(u, v, w, \tau)}{\partial w} d w d v d u d \tau ; \\
C_{11}(x, y, z, t) = & - \frac{2\pi}{L_x L_y L_z} \sum_{n=1}^{\infty} n F_{nC} c_n(x) c_n(y) c_n(z) e_{nC}(t) \int_0^t e_{nC}(-\tau) \int_0^{L_x} s_n(u) \int_0^{L_y} c_n(v) \int_0^{L_z} c_n(w) \times \\
& \times g_L(u, v, w, T) \frac{\partial C_{01}(u, v, w, \tau)}{\partial u} d w d v d u d \tau - \frac{2\pi}{L_x L_y^2 L_z} \sum_{n=1}^{\infty} n F_{nC} c_n(x) c_n(y) c_n(z) e_{nC}(t) \times \\
& \times \int_0^t e_{nC}(-\tau) \int_0^{L_x} c_n(u) \int_0^{L_y} s_n(v) \int_0^{L_z} c_n(w) g_L(u, v, w, T) \frac{\partial C_{01}(u, v, w, \tau)}{\partial v} d w d v d u d \tau - \frac{2\pi}{L_x L_y L_z^2} \times \\
& \times \sum_{n=1}^{\infty} n e_{nC}(t) \int_0^t e_{nC}(-\tau) \int_0^{L_x} c_n(u) \int_0^{L_y} c_n(v) \int_0^{L_z} s_n(w) g_L(u, v, w, T) \frac{\partial C_{01}(u, v, w, \tau)}{\partial w} d w d v d u d \tau \times \\
& \times F_{nC} c_n(x) c_n(y) c_n(z) - \frac{2\pi}{L_x^2 L_y L_z} \sum_{n=1}^{\infty} F_{nC} c_n(x) c_n(y) c_n(z) e_{nC}(t) \int_0^t e_{nC}(-\tau) \int_0^{L_x} s_n(u) \int_0^{L_y} c_n(v) \times \\
& \times n \int_0^{L_z} c_n(w) \frac{C_{00}^\gamma(u, v, w, \tau)}{P^\gamma(u, v, w, T)} \frac{\partial C_{10}(u, v, w, \tau)}{\partial u} d w d v d u d \tau - \frac{2\pi}{L_x L_y^2 L_z} \sum_{n=1}^{\infty} n F_{nC} c_n(x) c_n(y) \times \\
& \times c_n(z) e_{nC}(t) \int_0^t e_{nC}(-\tau) \int_0^{L_x} c_n(u) \int_0^{L_y} s_n(v) \int_0^{L_z} c_n(w) \frac{C_{00}^\gamma(u, v, w, \tau)}{P^\gamma(u, v, w, T)} \frac{\partial C_{10}(u, v, w, \tau)}{\partial v} d w d v d u d \tau - \\
& - \frac{2\pi}{L_x L_y L_z} \sum_{n=1}^{\infty} n F_{nC} c_n(x) c_n(y) c_n(z) e_{nC}(t) \int_0^t e_{nC}(-\tau) \int_0^{L_x} c_n(u) \int_0^{L_y} c_n(v) \int_0^{L_z} s_n(w) \frac{C_{00}^\gamma(u, v, w, \tau)}{P^\gamma(u, v, w, T)} \times \\
& \times \frac{\partial C_{10}(u, v, w, \tau)}{\partial w} d w d v d u d \tau - \frac{2\pi}{L_x^2 L_y L_z} \sum_{n=1}^{\infty} n F_{nC} c_n(x) c_n(y) c_n(z) e_{nC}(t) \int_0^t e_{nC}(-\tau) \int_0^{L_x} s_n(u) \times \\
& \times \int_0^{L_y} c_n(v) \int_0^{L_z} c_n(w) C_{10}(u, v, w, \tau) \frac{C_{00}^{\gamma-1}(u, v, w, \tau)}{P^\gamma(u, v, w, T)} \frac{\partial C_{00}(u, v, w, \tau)}{\partial u} d w d v d u d \tau - \frac{2\pi}{L_x L_y^2 L_z} \sum_{n=1}^{\infty} n \times
\end{aligned}$$

$$\begin{aligned}
& \times F_{nC} c_n(x) c_n(y) c_n(z) e_{nC}(t) \int_0^t e_{nC}(-\tau) \int_0^{L_x} c_n(u) \int_0^{L_y} s_n(v) \int_0^{L_z} c_n(w) \frac{C_{00}^{\gamma-1}(u, v, w, \tau)}{P^\gamma(u, v, w, T)} \frac{\partial C_{00}(u, v, w, \tau)}{\partial v} \times \\
& \times C_{10}(u, v, w, \tau) d w d v d u d \tau - \frac{2\pi}{L_x L_y L_z^2} \sum_{n=1}^{\infty} n F_{nC} c_n(x) c_n(y) c_n(z) e_{nC}(t) \int_0^t e_{nC}(-\tau) \int_0^{L_x} c_n(u) \times \\
& \times \int_0^{L_y} c_n(v) \int_0^{L_z} s_n(w) C_{10}(u, v, w, \tau) \frac{C_{00}^{\gamma-1}(u, v, w, \tau)}{P^\gamma(u, v, w, T)} \frac{\partial C_{00}(u, v, w, \tau)}{\partial w} d w d v d u d \tau .
\end{aligned}$$